



flexible by design



SOLUTIONS FOR PERMANENT OR TEMPORARY USE

WiikHall

Wiiking II Aluminium, 10 meters span
Assembly guide – 10 x 24 m

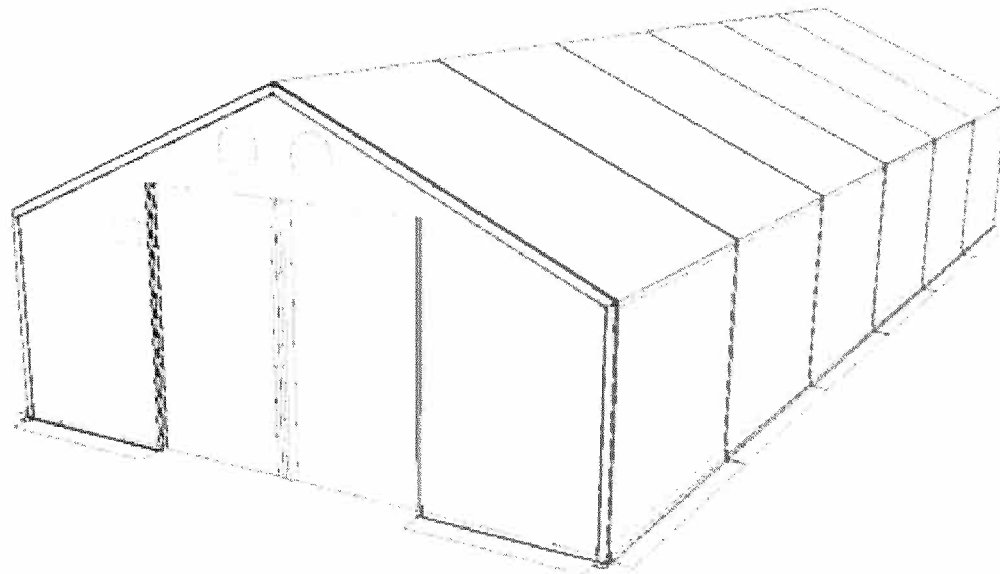

Contents:

1. Technical data
2. Parts list
3. Assembly guide

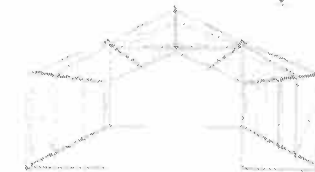

1. Technical data

for Wiiking II Aluminium 10 meters

Wiiking Aluminium is dimensioned for the following loads:

- Windloads: 0.65 kN/m²
- Snowloads: 0.75 kN/m²

Technical characteristics of fabric:

- The fabric is flame retardant and approved in accordance with SIS 650082
- The temperature resistance: between -30°C and +70 °C

Total weight:

- Gross weight per unit 10x24m: 2371 kilos





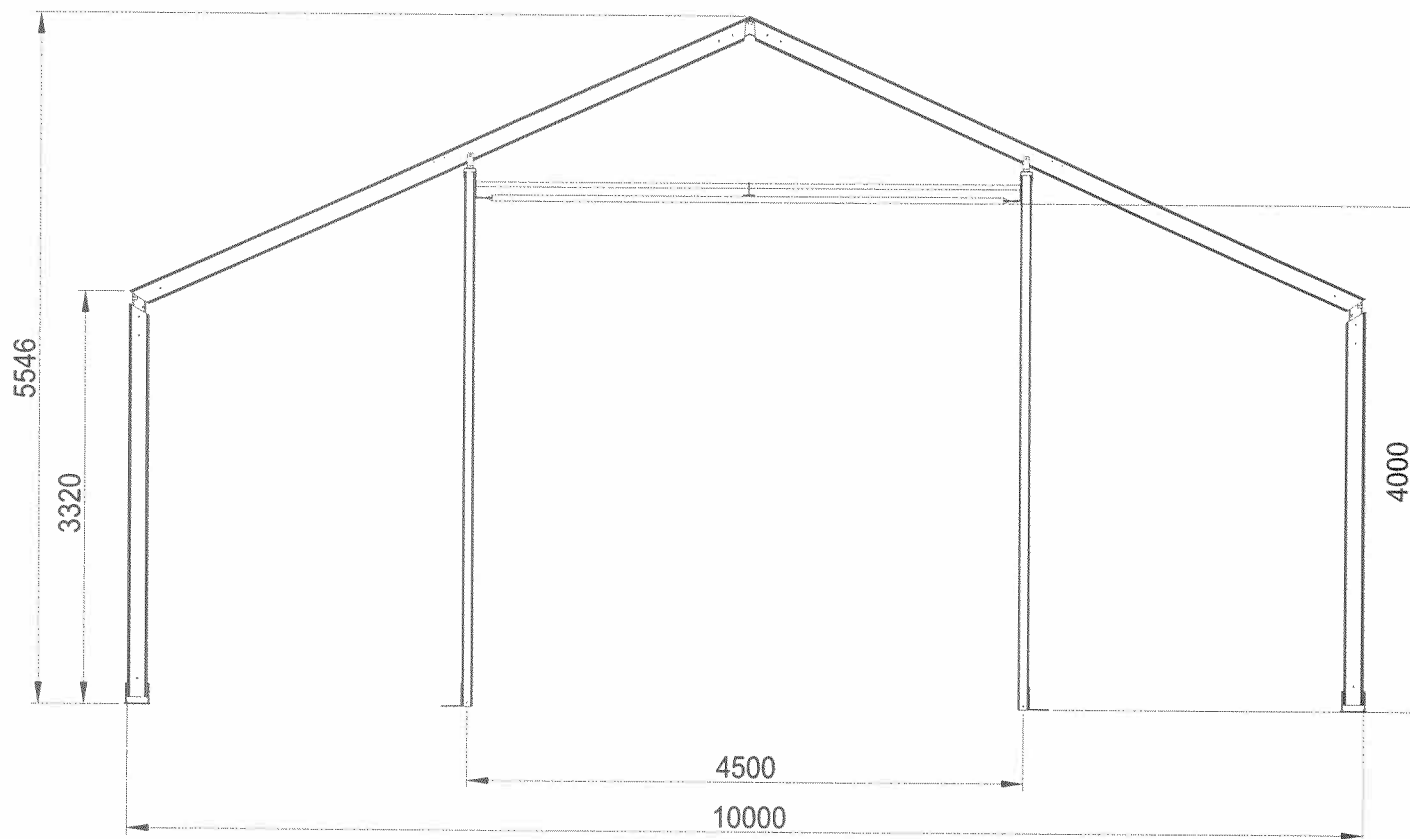





Max length, cargo:







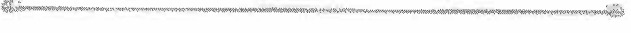
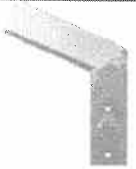

- Length: 5.5 meters

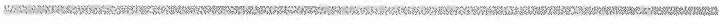
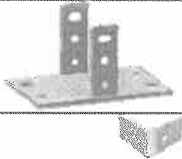

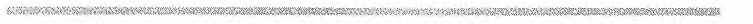



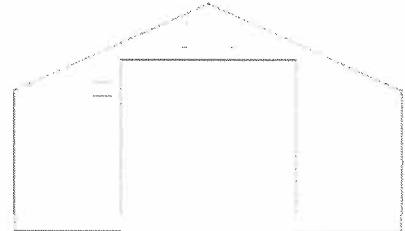





2.Parts list 10 x 24 m for Wiiking II Aluminium 10 meters

ID/Item	Component	Weight (kg)/piece	Height/length (mm)	Drawings	Quantity
1	Leg	14,5	H=3140		14
2	Half truss	25	L=5473		14
2a	Bracket for purlin	0,14			28
3	Gable suspension beam	13	L=4408		1
3a	Loop	0,1			10
4	Gable column	10	H=4292		4
4a	Gable beam, top connection	1,3			4
4b	Gable column, base plate	1,2			4
5	Upper tension bar, Above gate	16	L=4395		1
6	Corner joint	9,5			14
7	Roof apex	6,5			7

ID/Item	Component	Weight (kg)/piece	Height/length (mm)	Drawings	Quantity
8	Lateral ground bar	14,5	L=4000		12
8a	Lateral clamp list	3,7	L=3930		12
9	Base plate	5,5			14
10	Gable ground bar support	0,2			4
12	Gable ground bar	10	L=2798		4
12a	Gable clamp list	2,3	L=2500		4
13	Purlin	12,27	L=3869		30
14	Counter bracing cable, roof. Red label	2,4	L=6350		8
15	Counter bracing cable, wall. Green label	1,5	L=4883		8
16	Cover, gable end A	24,2			1
17	Gate fabric, gable end A.	7,7			2

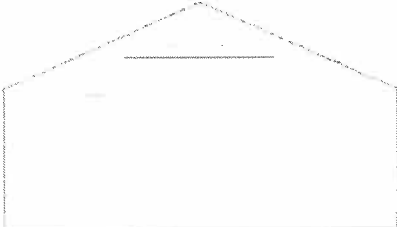
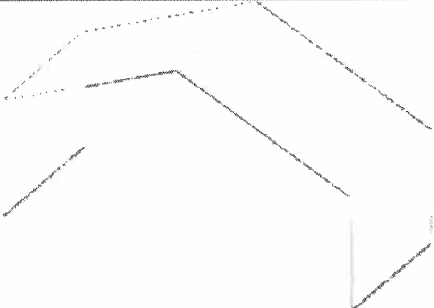

ID/Item	Component	Weight (kg)/piece	Height/length (mm)	Drawings	Quantity
18	Gate column	18	L=4090		2
18a	Gate column suspension loop	0,5			2
18b	Handle, locking device	0,8			1
18c	Housing, locking device	0,2			2
18d	Sliding bolt, locking device	0,9			1
18e	Locking bracket	0,1	L=250		2
19	Cover, gable end B	38,5			1
20	Roof cover	56			6
21	Gable tension bar	2,2	L=2300		4
22	Lateral tension bar	3,5	L=3700		12

Auxiliaries:

Padlock



Tool kit



Spade

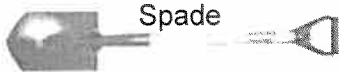

Ladder



Lifting fork for purlin



Sledgehammer



Measuring tape



Ropes



Fixing device:

Quantity	Component	Type / Dimension
28	Hex bolt	M8x90
28	Hex nut	M8
56	Washer Ø8,4	
116	Hex bolt, full threaded	M12x30
94	Hex bolt	M12x90
12	Hex bolt	M12x120
214	Hex nut	M12
8	Square washer	M12
420	Washer Ø13	
4	Hex bolt	M16x100
4	Hex bolt	M16x130
28	Hex bolt	M16x220
36	Hex nut	M16
72	Washer Ø17	
8	Eye nut	M12
2	Bushings, for locking device Ø16	Ø16
32	Shackle	M10
32	Straps	
32	Groundspike	Ø20x800

3. Assembling guide

Wiiking II Aluminium 10 meters

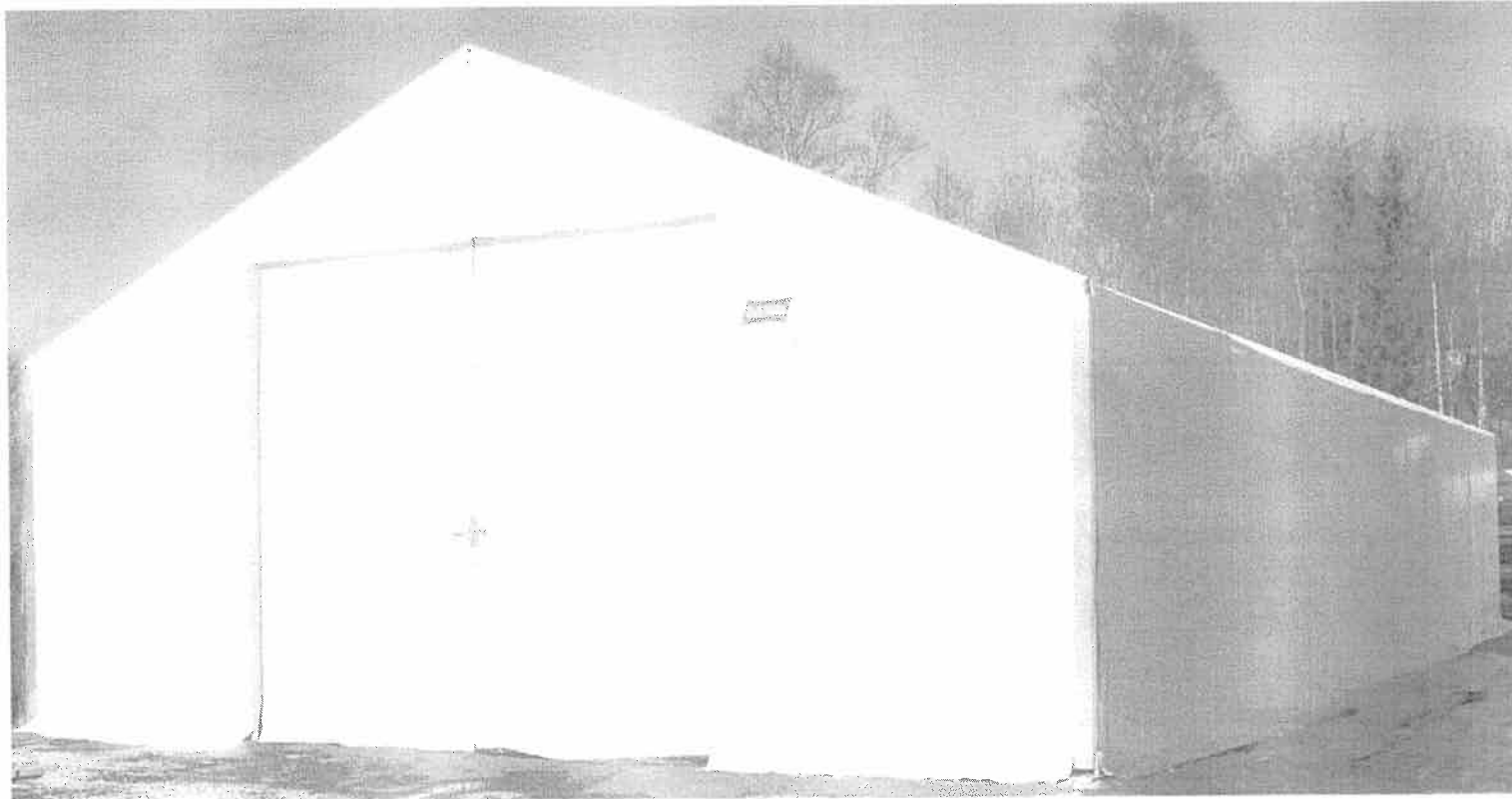

Ensure that you have received all the parts required and that they are undamaged.

Before assembling the equipment, study this document carefully.

Ensure that your working area is free of possible sources of danger.

Use the fastening material exactly as instructed. The required tools are supplied with the equipment.

Installation team is recommended to consist of min. 6 persons.

Table of contents

3.1 Parts assembly

- [3.1.1 Base plan](#)
- [3.1.2 How to assemble the gable portal](#)
- [3.1.3 How to assemble the second portal](#)
- [3.1.4 How to assemble the third portal](#)
- [3.1.5 The complete assembly of portals on the ground](#)
- [3.1.6 og 3.1.7 Gable columns left and right](#)
- [3.1.8 Gable suspension and purlins](#)

3.2 The gable end A

- [3.2.1 How to fit the cover, gable end A](#)
- [3.2.2 Upper tension bar](#)
- [3.2.3 Gable columns](#)
- [3.2.4 Assembly of gable column top connection](#)
- [3.2.5 Gate suspension beam](#)
- [3.2.6 Assembly of gate suspension beam](#)
- [3.2.7 Gate cover](#)
- [3.2.8 Gate column](#)
- [3.2.9 Assembly of the gate column](#)

3.3 How to erect the portals

- [3.3.1 Erecting the first complete portal](#)
- [3.3.2 Second portal](#)
- [3.3.3 The ridge purlin](#)
- [3.3.4 Wall bracing cables](#)
- [3.3.5 Roof bracing cables](#)
- [3.3.6 Third portal](#)
- [3.3.7 The second last portal](#)
- [3.3.8 Last portal](#)

3.4 The gable end B

- [3.4.1 How to fit the cover, gable end B](#)

3.5 How to erect the Final gable end

- [3.5.1 The final gable end](#)

3.6 Anchoring

- [3.6.1 How to anchor the baseplates](#)

3.7 How to fit the roof cover

- [3.7.1 Fitting the roof cover](#)
- [3.7.2 Pull the cover to the opposite side](#)
- [3.7.3 Covering the walls](#)
- [3.7.4 How to secure the covers](#)

3.8 The locking-system

- [3.8 The locking-system](#)

3.9 Safety measure

- [3.9.1 Handling the equipment](#)

3.1.1 Base plan.

1. Place the base plates, item9 and the lateral ground bars, item8 on the ground.
2. Measure the width and the diagonals, please see detail A for the reference point.
3. Place the lateral ground bars between the base plates with M12x30mm bolt, washers and M12 nut.
4. One ground spike must be hammered into the ground on each first base plate (to secure the position).

Secure the first ground spike here

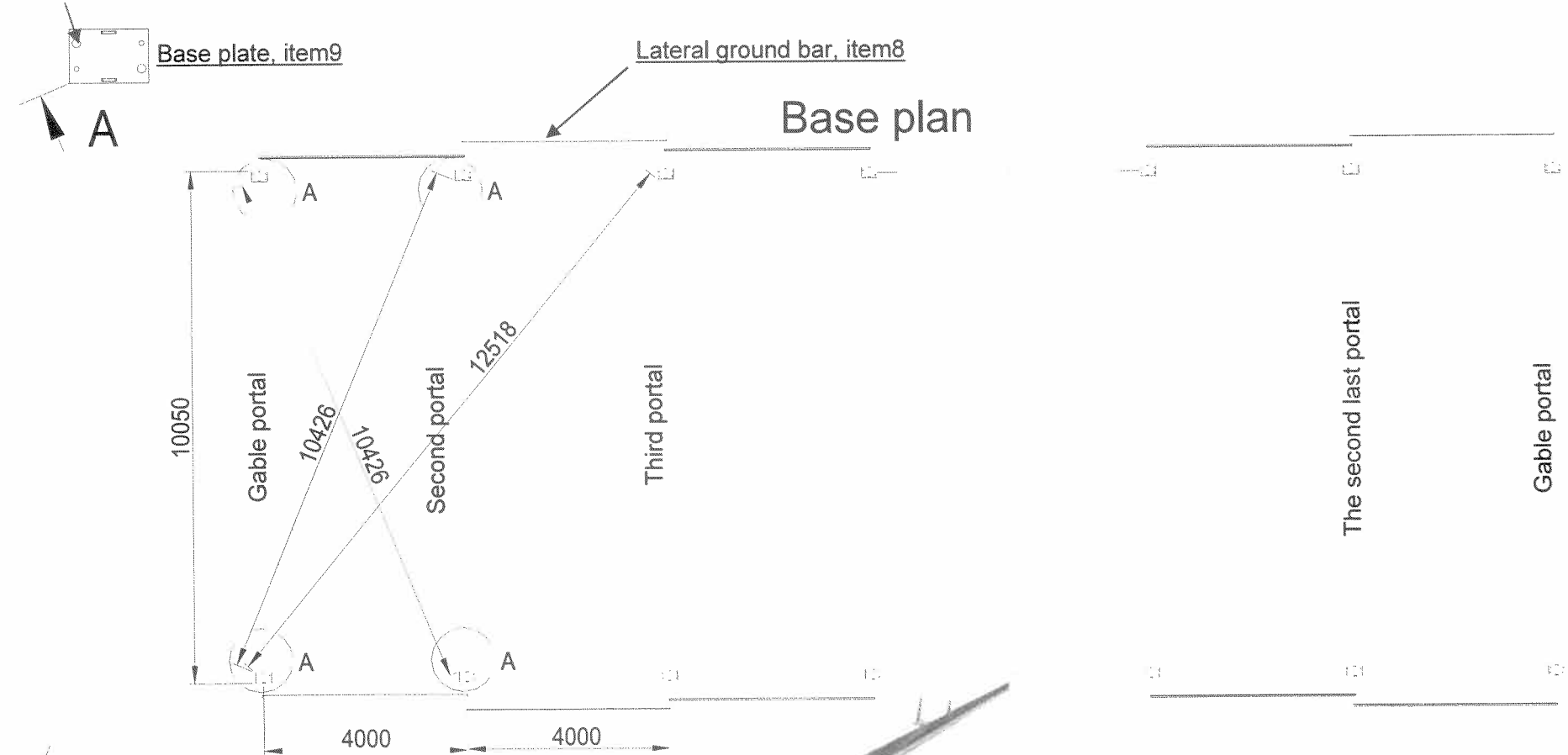

Secure the first ground spike here

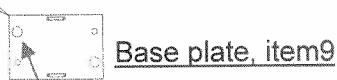

Secure the first ground spike here

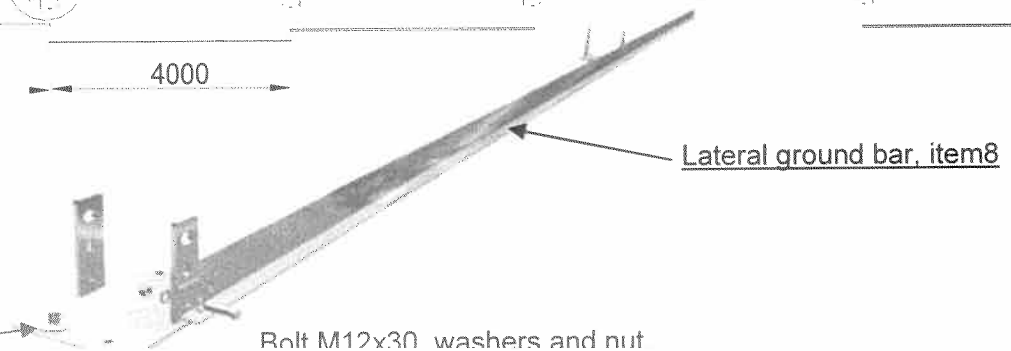

3.1.2 How to assemble the gable portal.

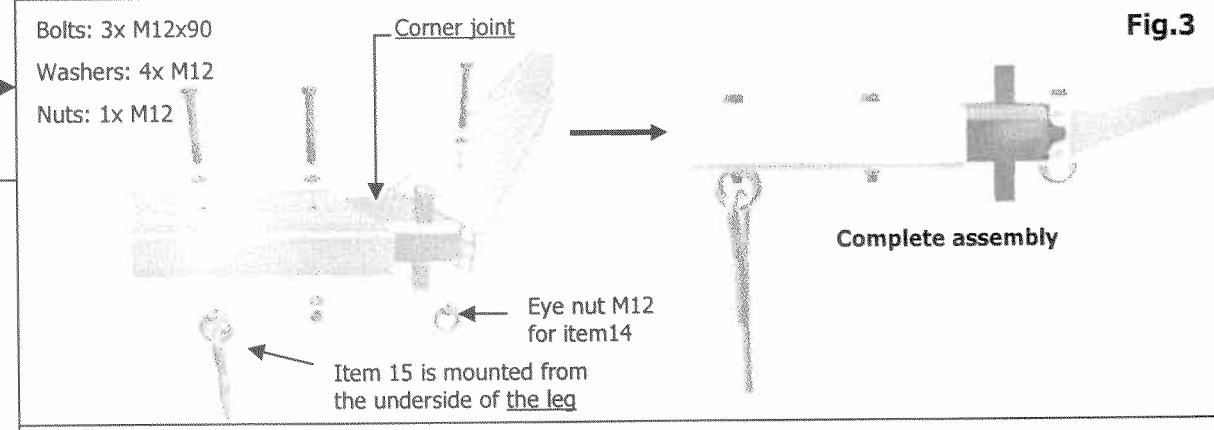
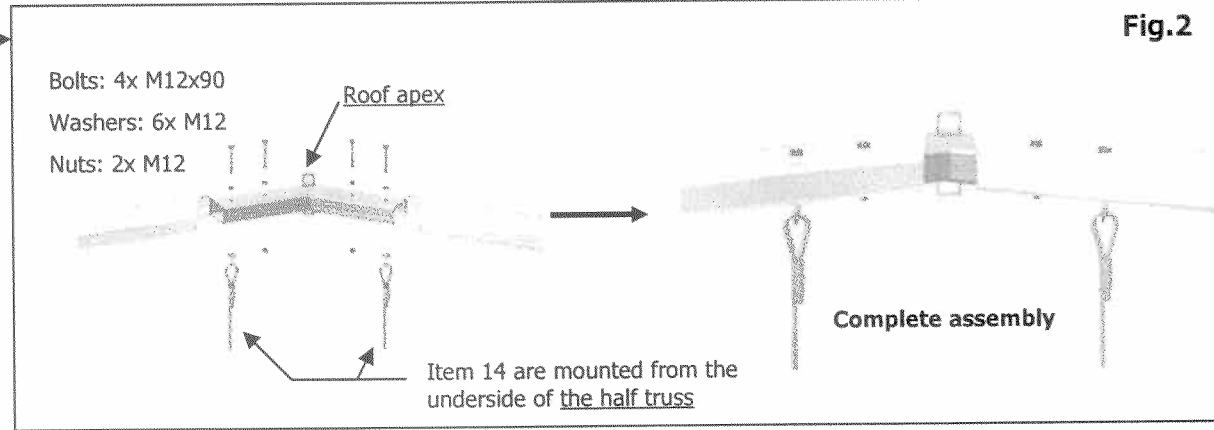
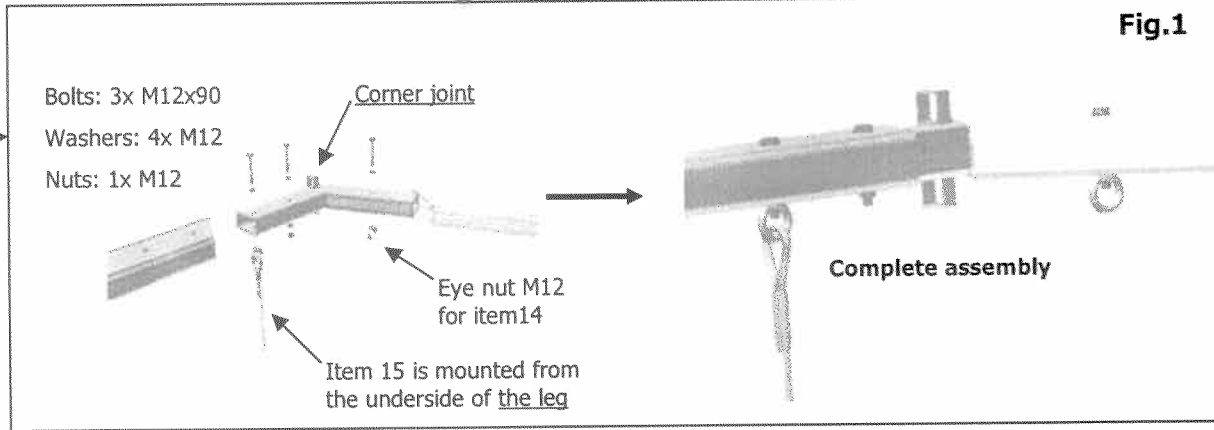
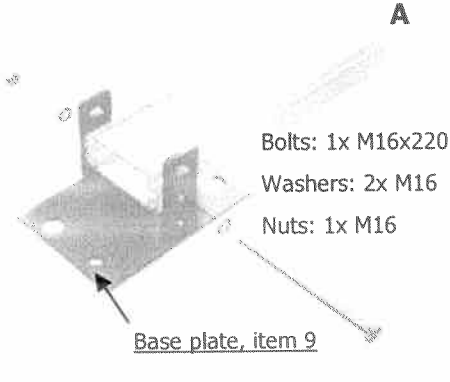
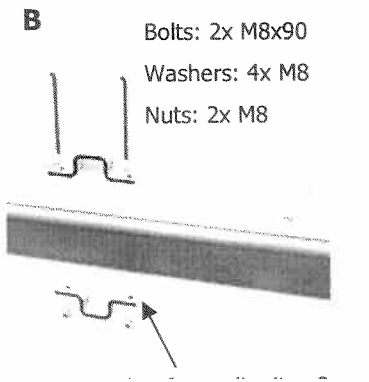
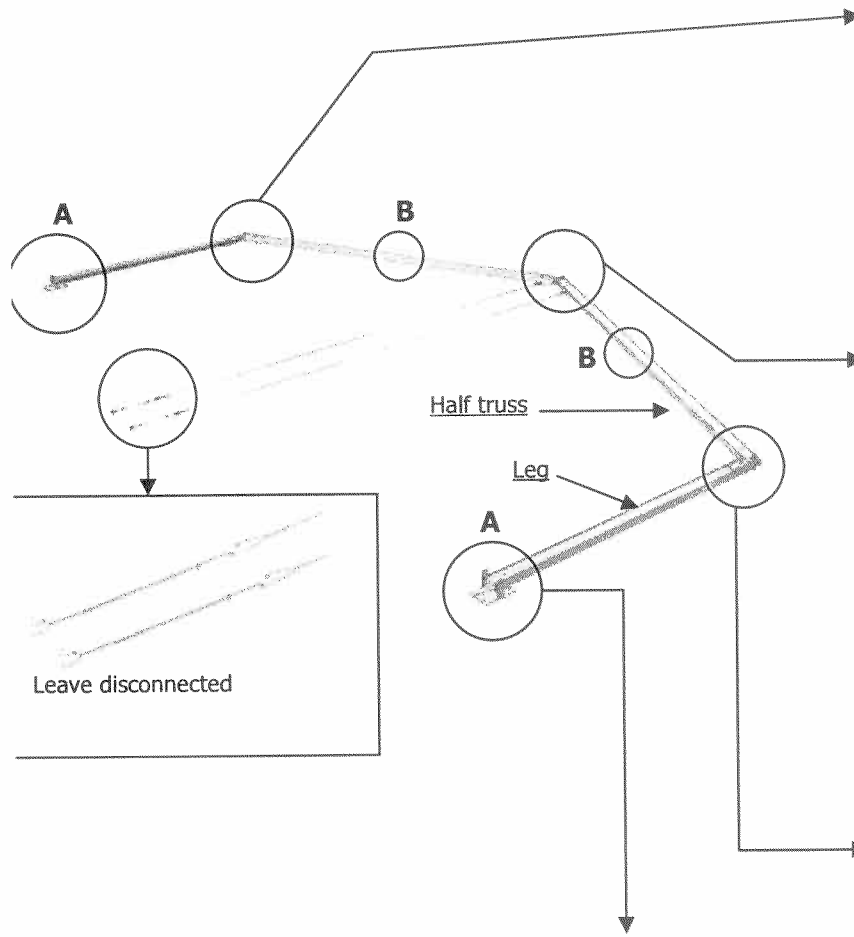

3.1.3 How to assemble the second portal.

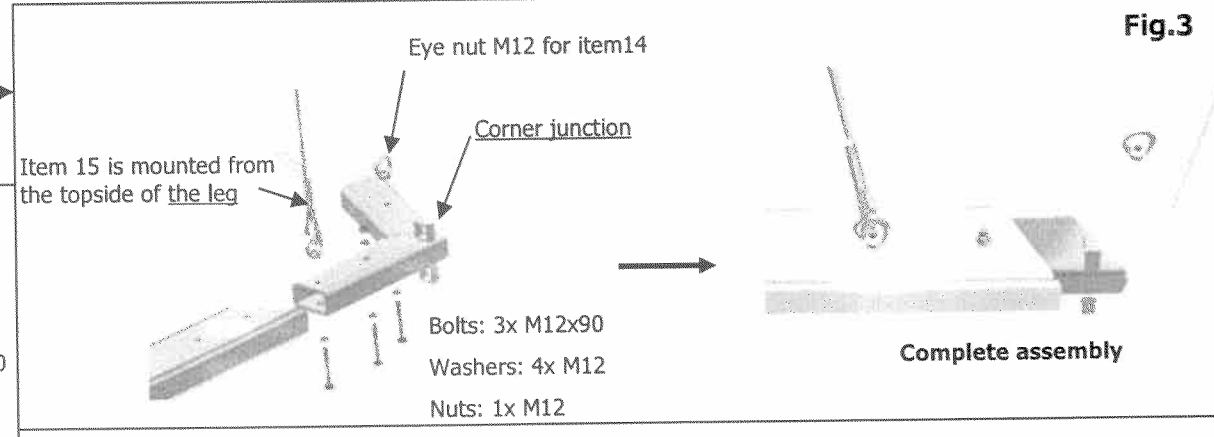
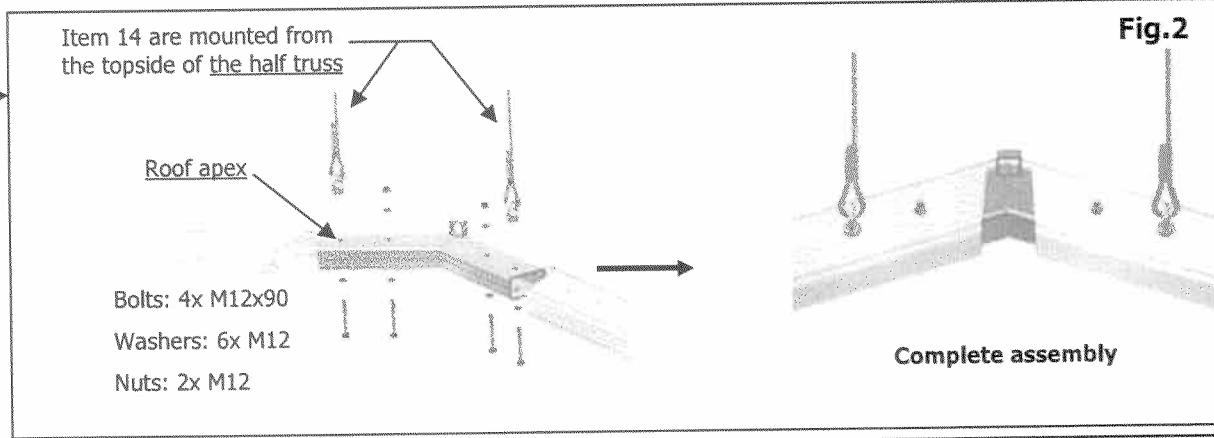
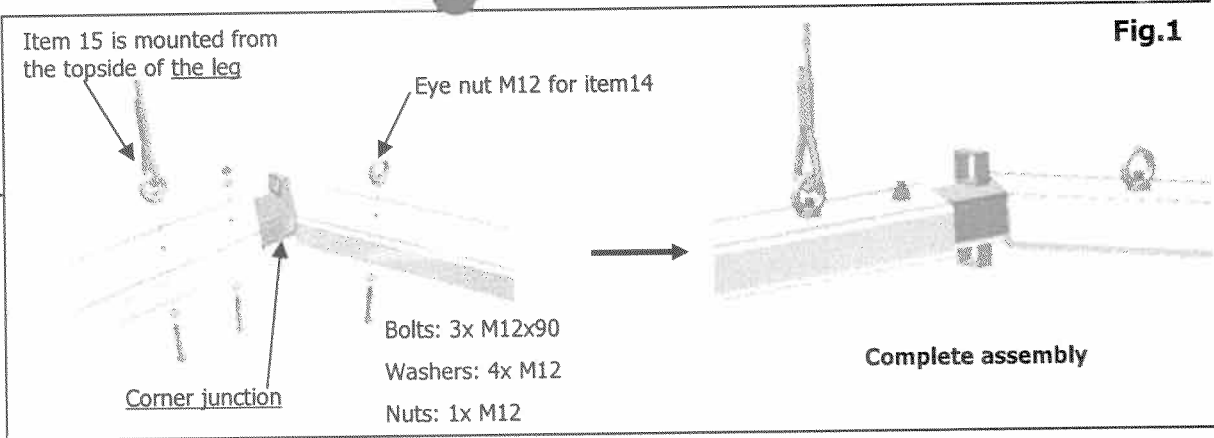
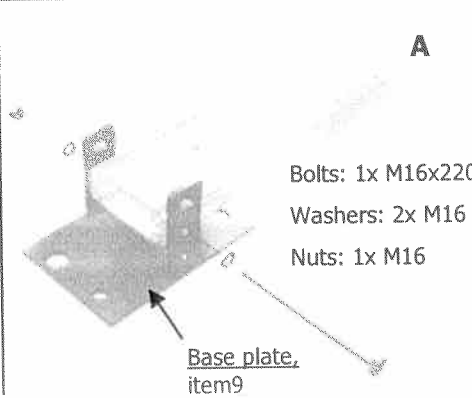
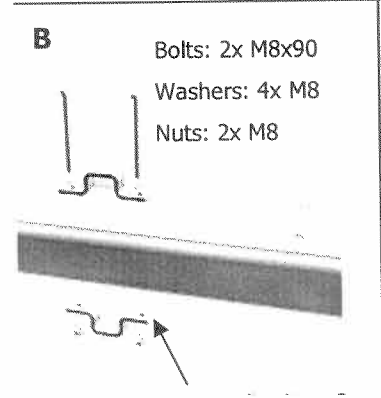
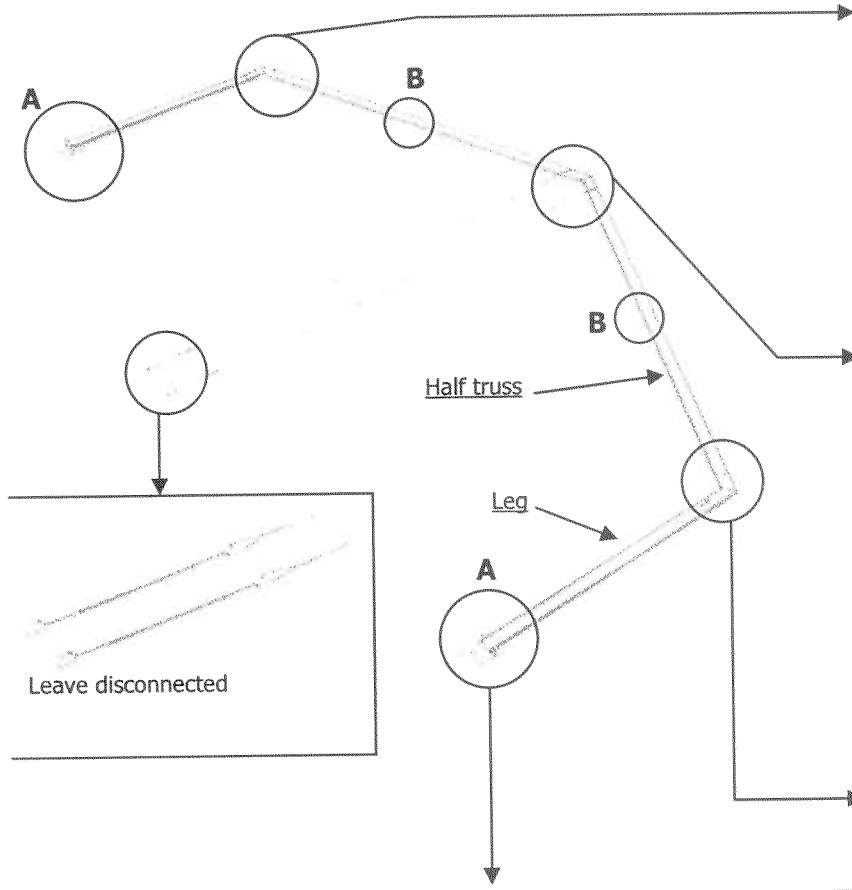

3.1.4 How to assemble the third portal.

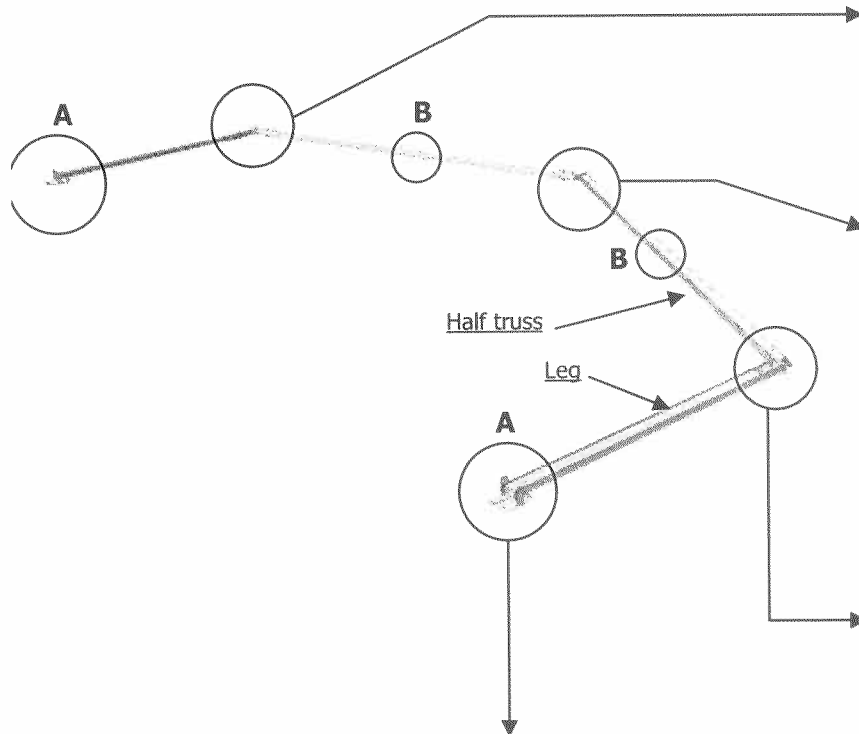

Bolts: 3x M12x90
Washers: 6x M12
Nuts: 3x M12

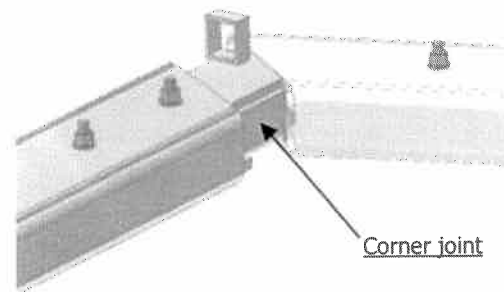

Fig.1

Bolts: 4x M12x90
Washers: 8x M12
Nuts: 4x M12

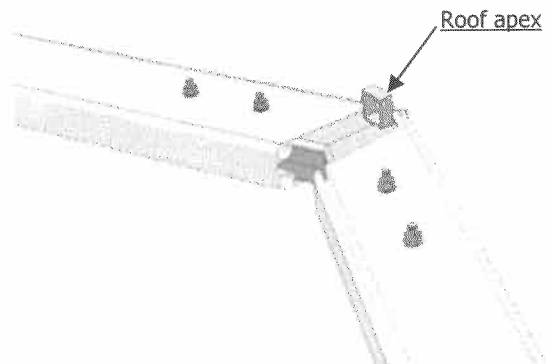

Fig.2

Bolts: 3x M12x90
Washers: 6x M12
Nuts: 6x M12

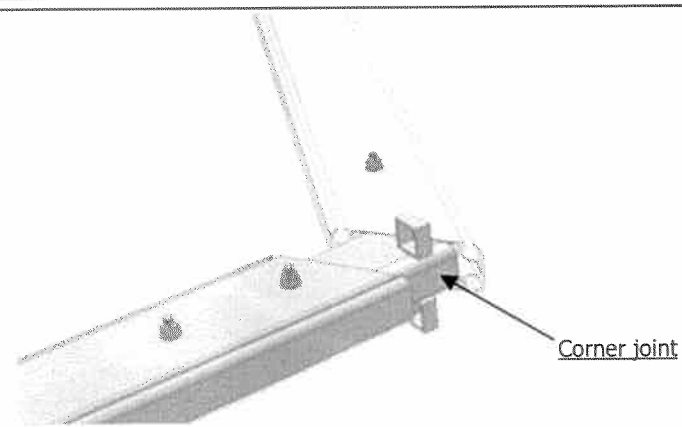
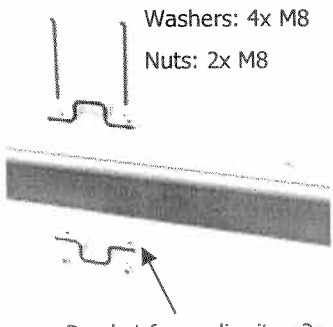
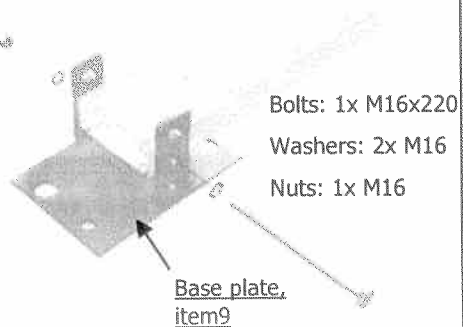

Fig.3

B
Bolts: 2x M8x90
Washers: 4x M8
Nuts: 2x M8



A
Bolts: 1x M16x220
Washers: 2x M16
Nuts: 1x M16



3.1.5 The complete assembly of portals on the ground

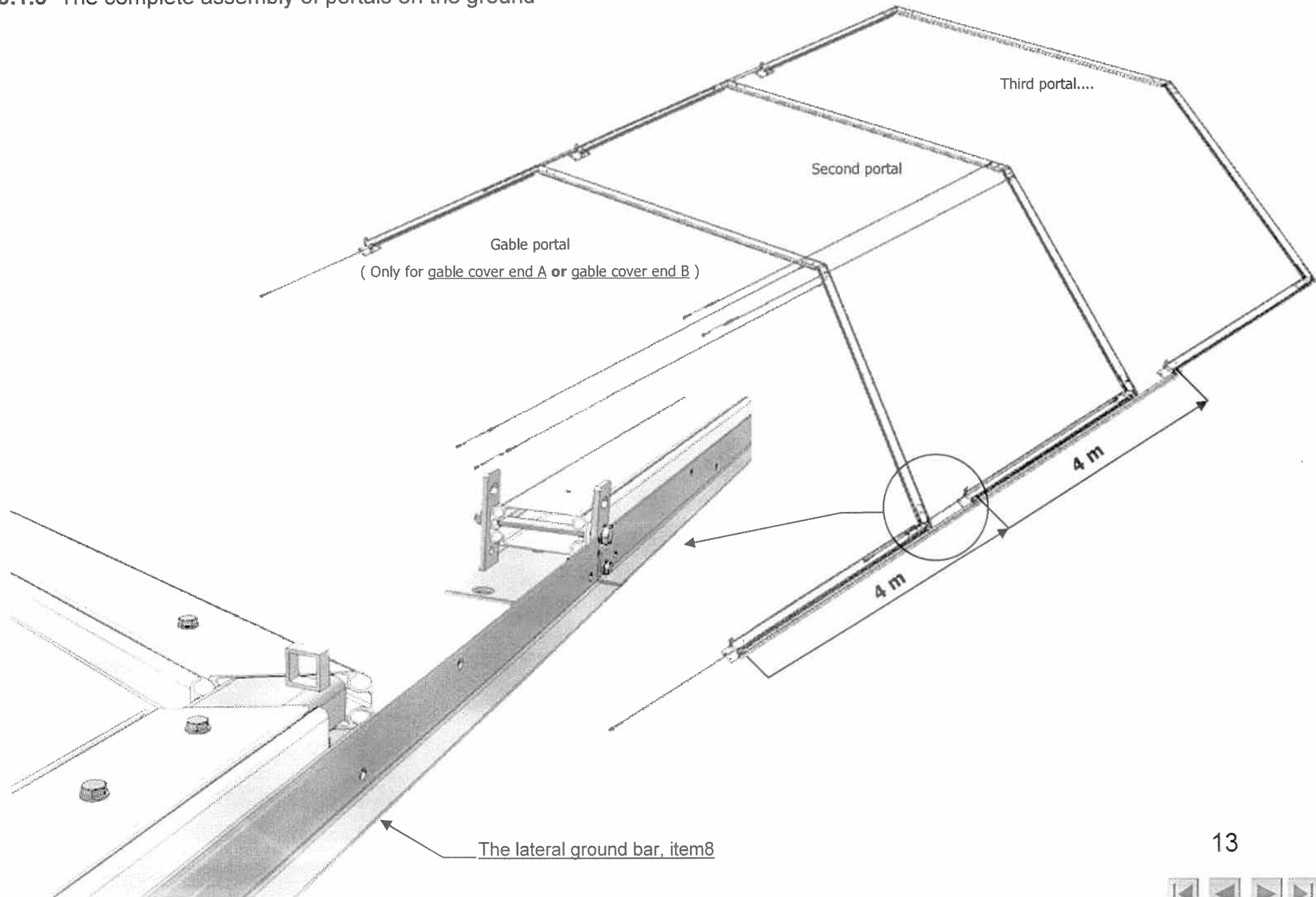

3.1.6 The gable column L

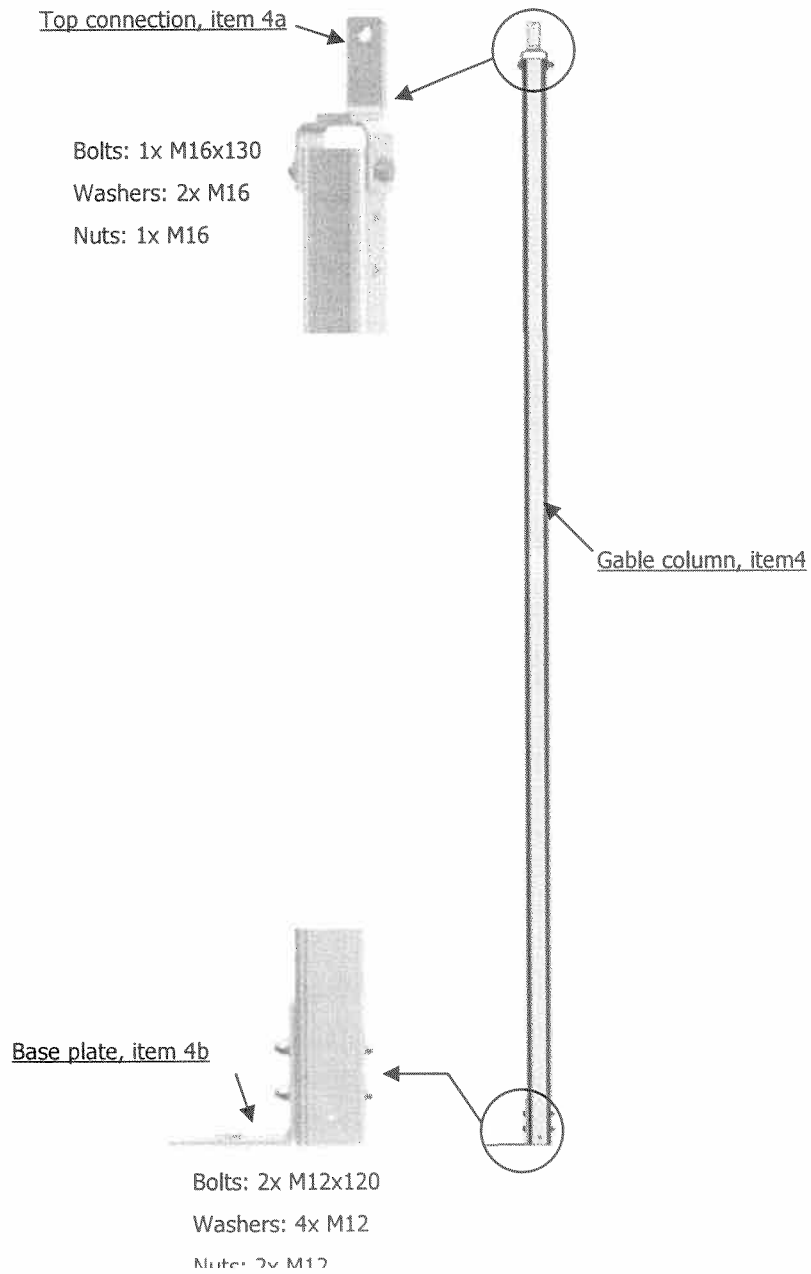

3.1.7 The gable column R

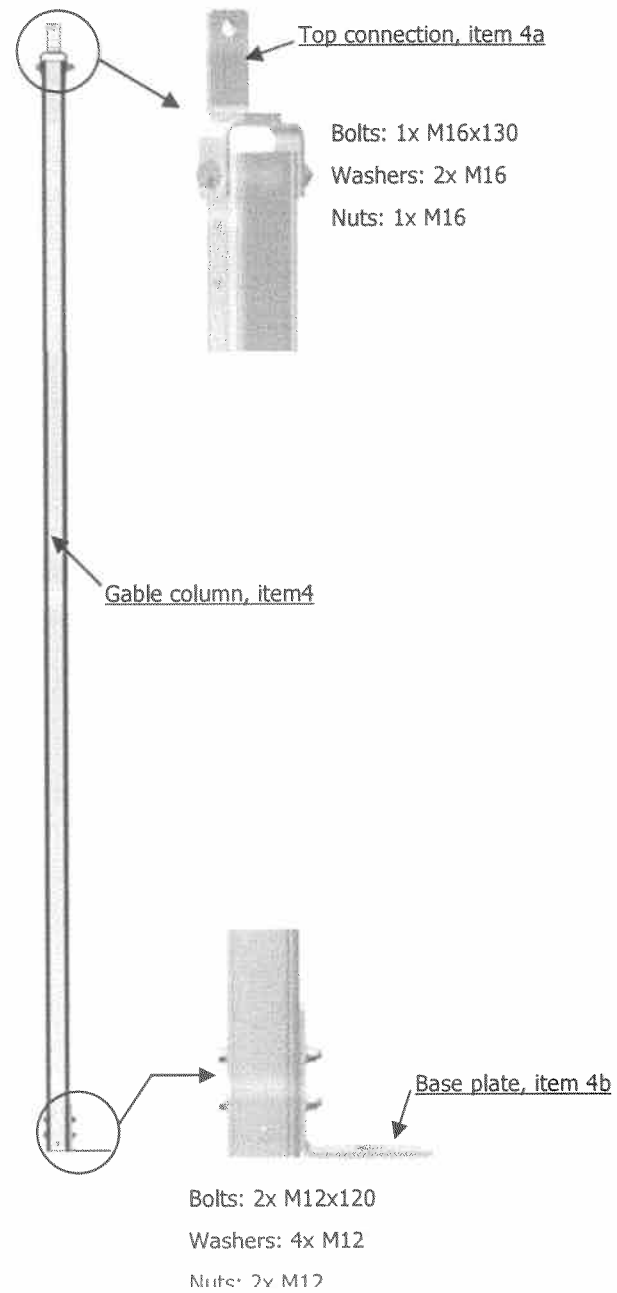

3.1.8 Gable suspension beam and purlins

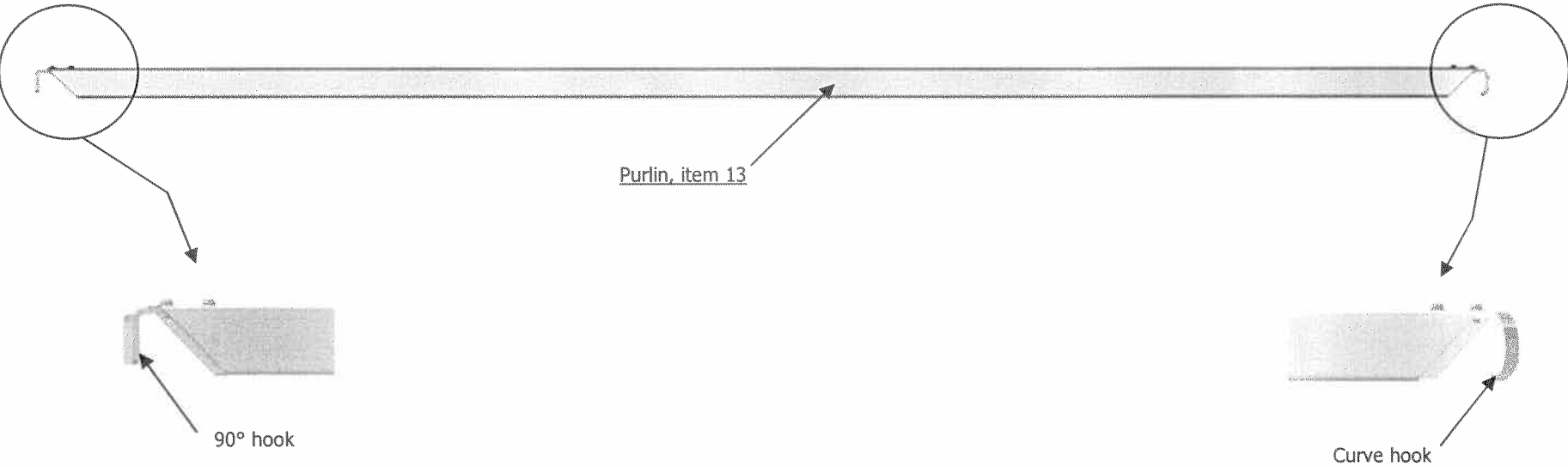
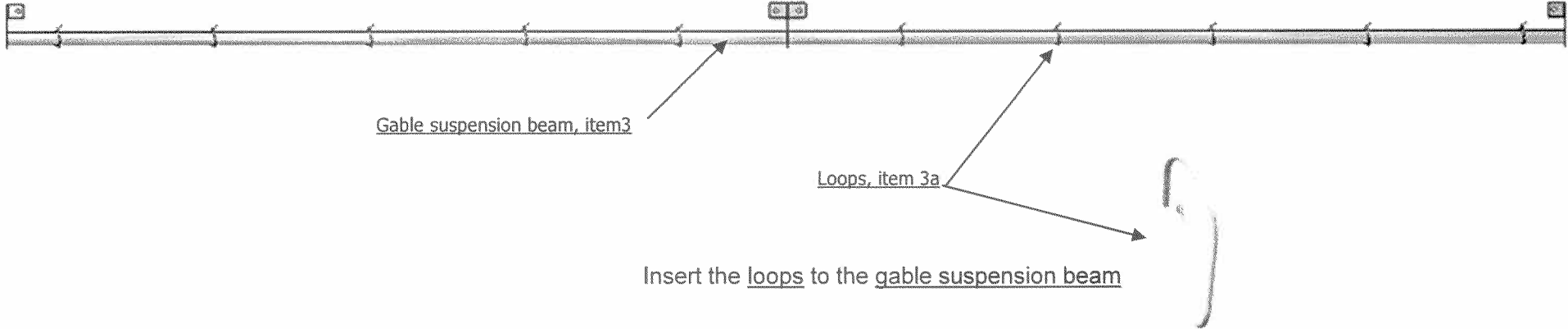

3.2 The gable end A.

3.2.1 How to fit the cover, gable end A.

A) Start fitting gable end A, to the half trusses, item2, by sliding it into the lower keder track of first half truss, then on the opposite one.

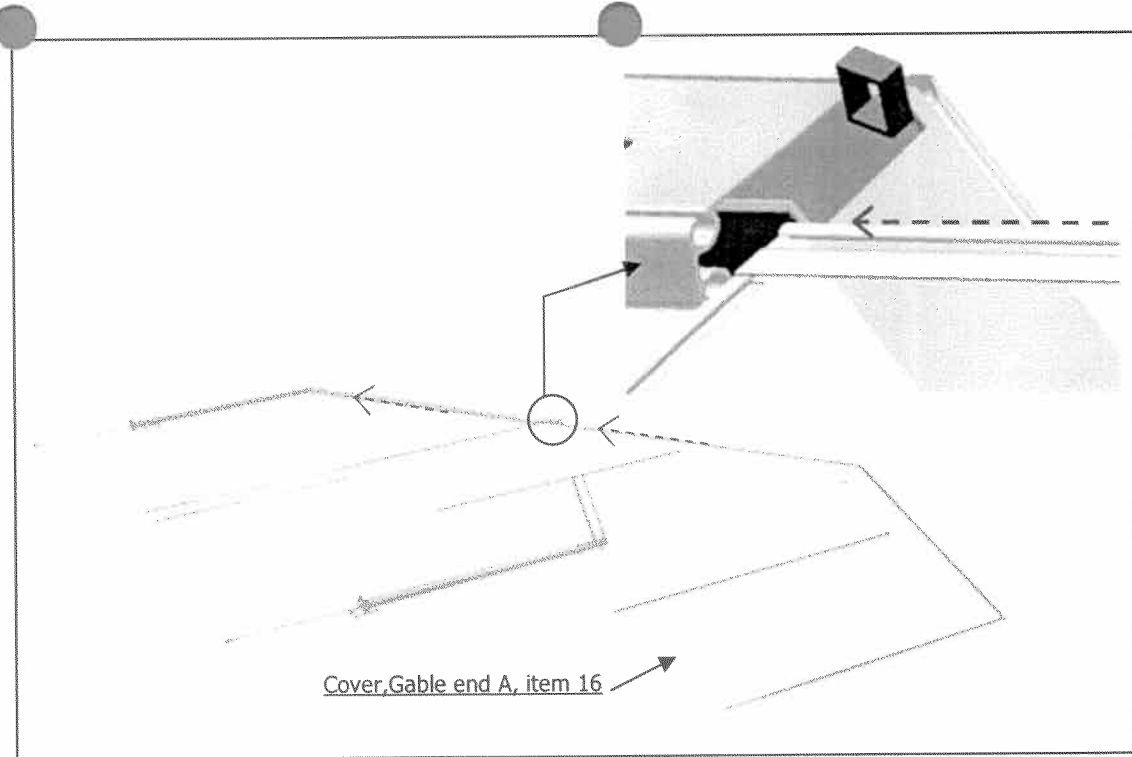

B) ... then slide the gable end A into the inner keder tracks of the legs, item1.

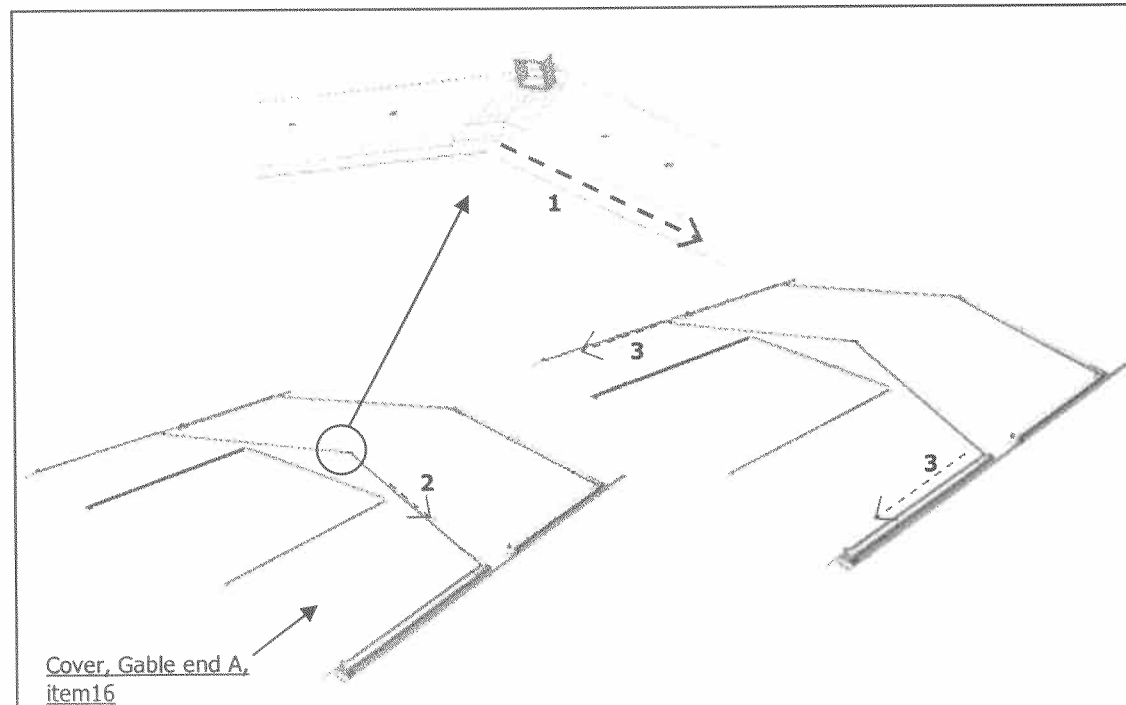

3.2.2 Insert the upper tension bar, item5 into the fabric pocket.

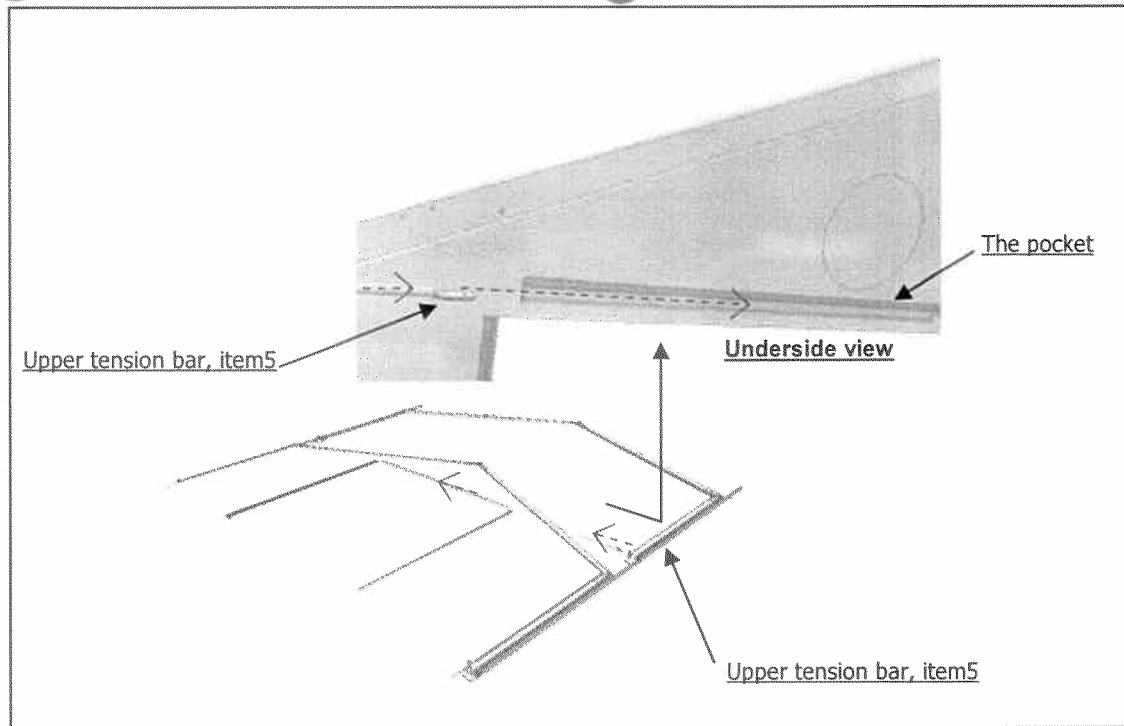

3.2.3 Pulling of gable columns.

Sliding in the gable columns. Use the outermost keder track of the gable columns.

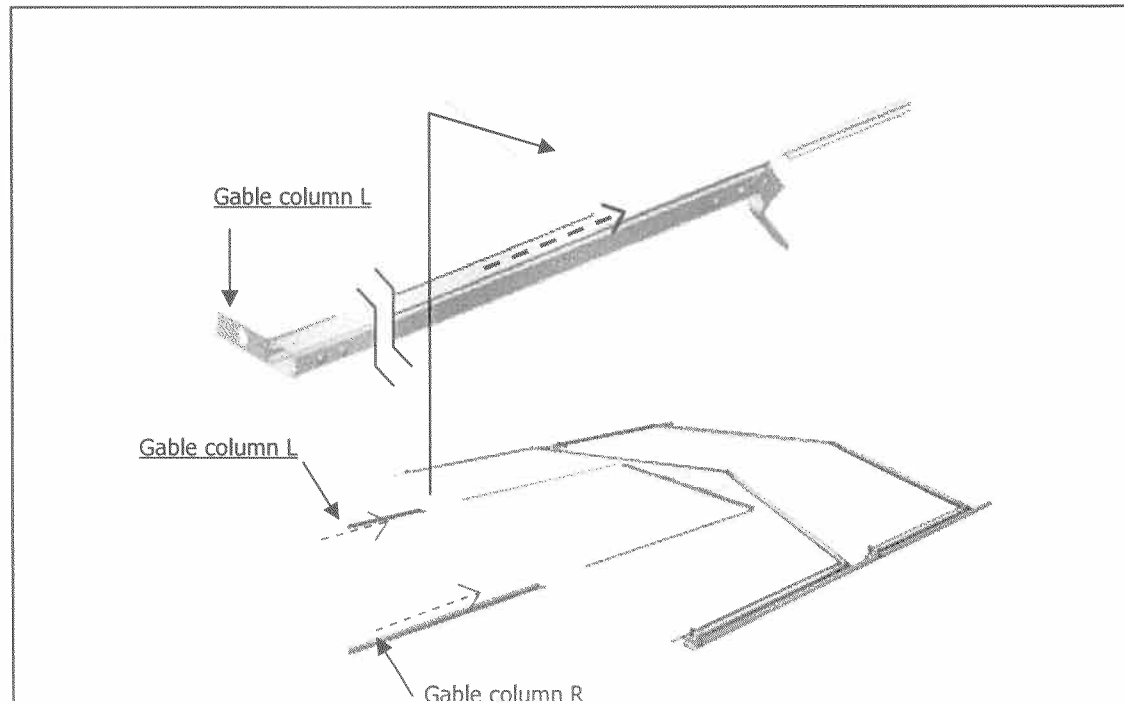

3.2.4 Assembly of gable column, top connection.

The gable columns, top connection must be fixed to the half trusses.

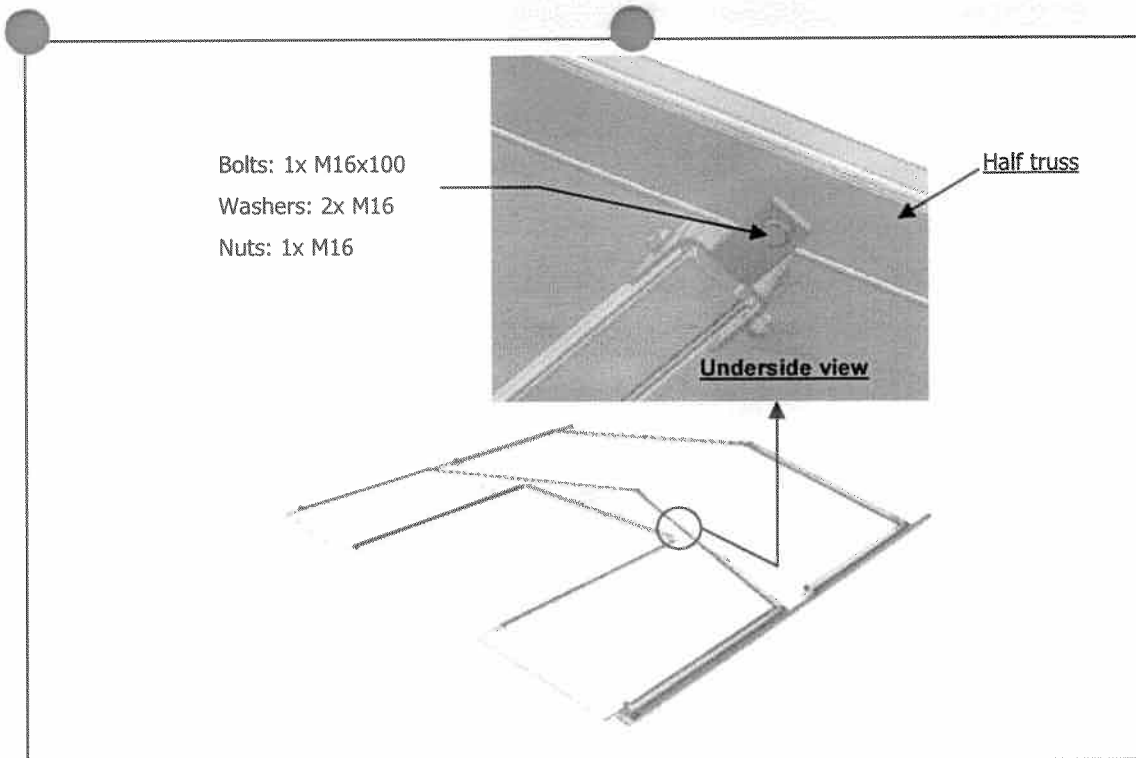

3.2.5 Placing of gate suspension beam, item3.

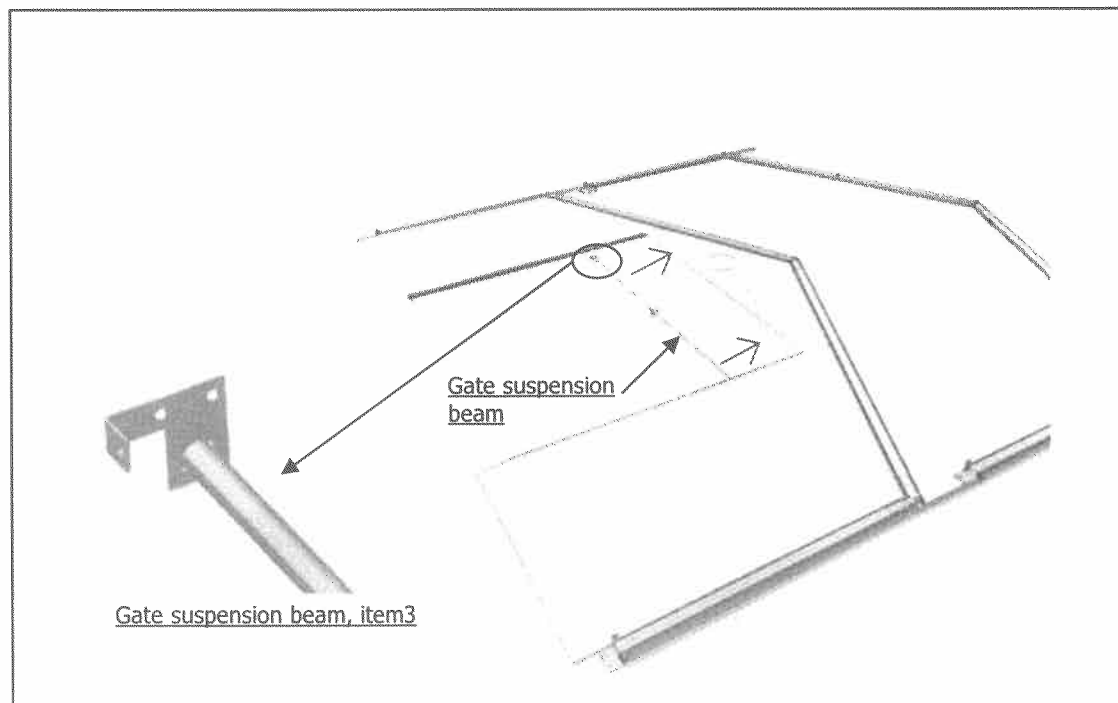

3.2.6 Assembly of gate suspension beam.

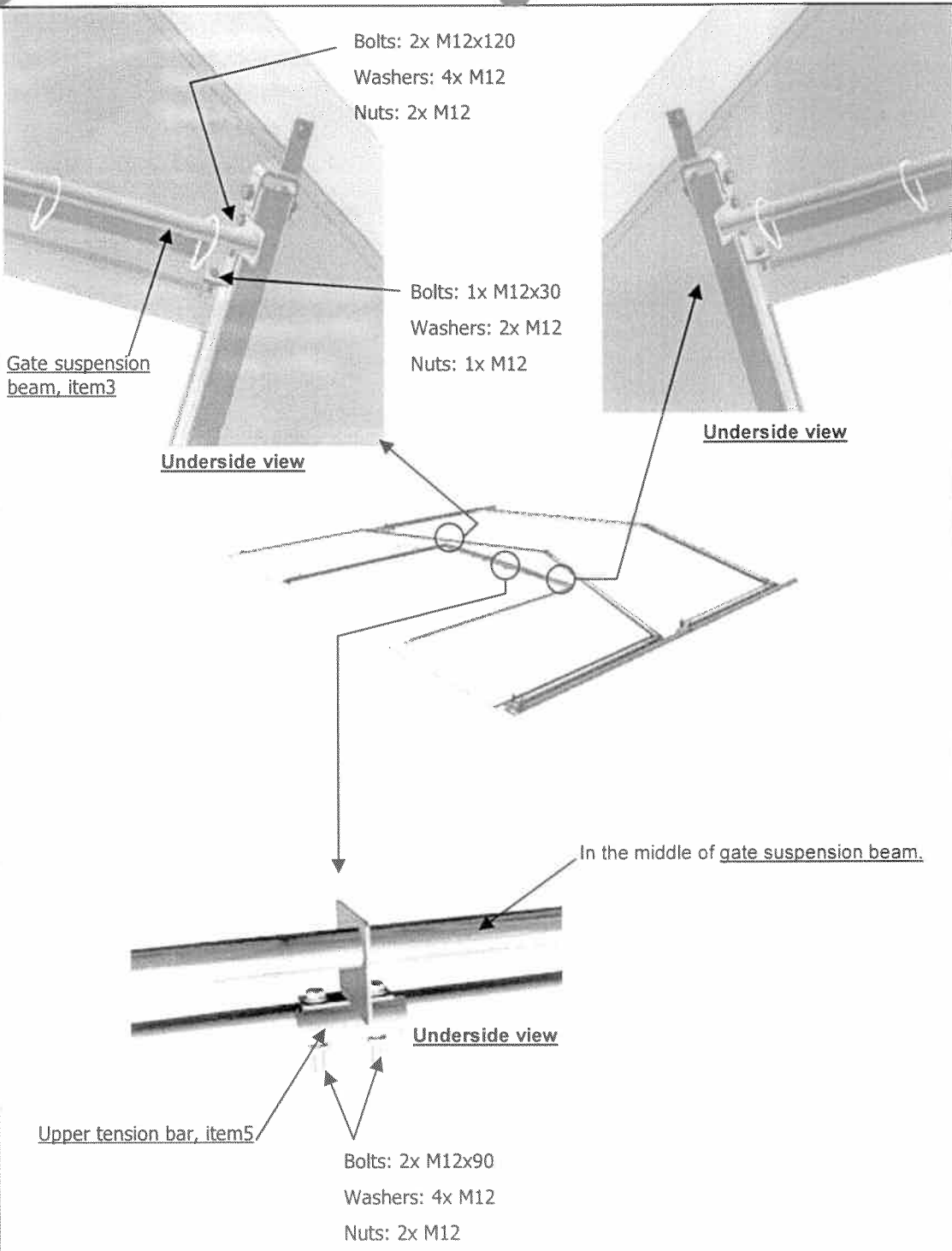

3.2.7 Placing of gate cover, item17.

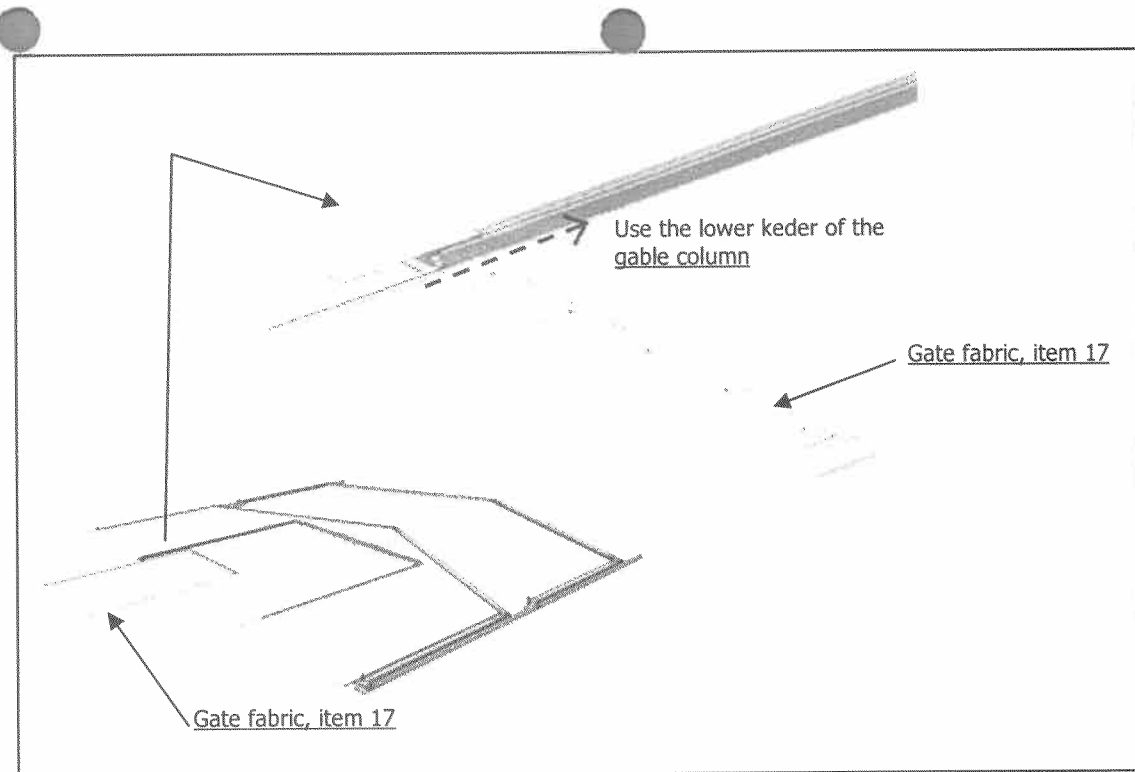

3.2.8 Pulling of gate column, item18 into the fabric pocket.

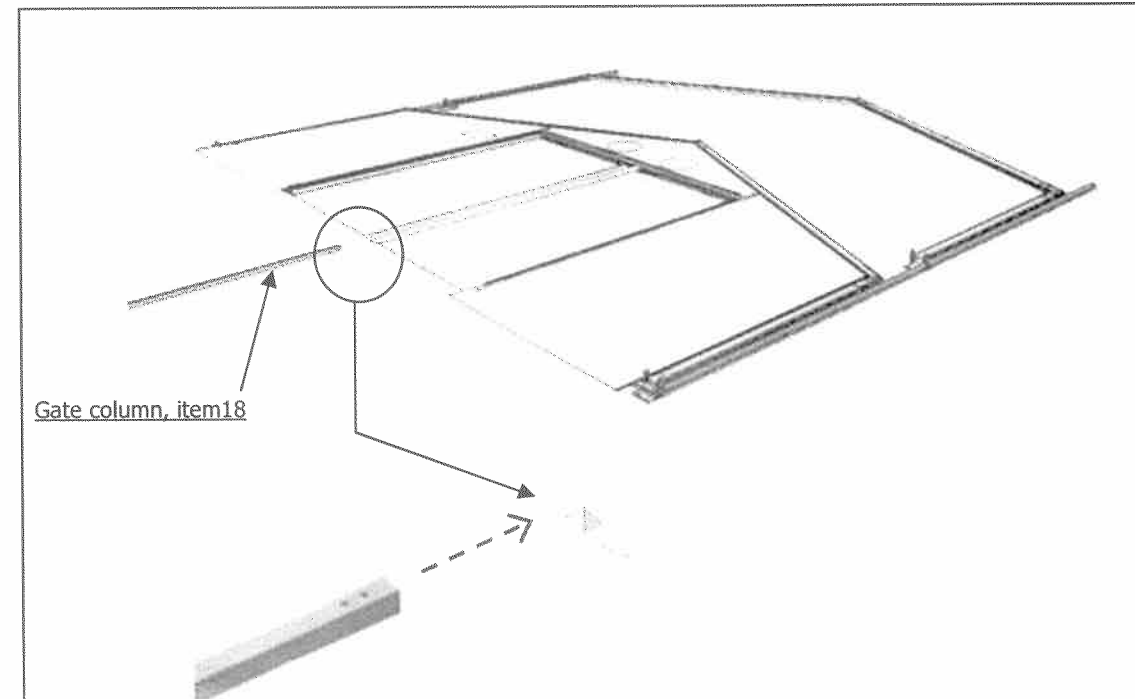

3.2.9 Assembly of the Gate columns.

Gate columns, item 18 must be bolted together with the gate column suspension loop, item 18a.

Made 2 small holes in the gate fabric in order to connect the gate column suspension loop.

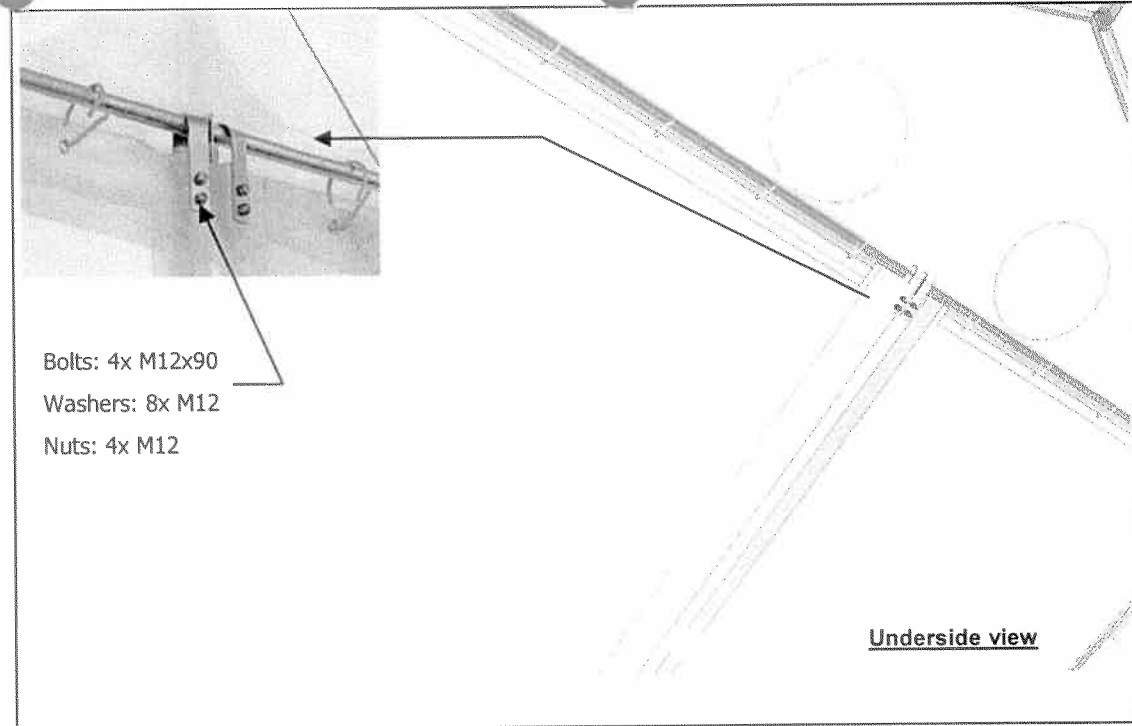

Complete assembly of gable end A.

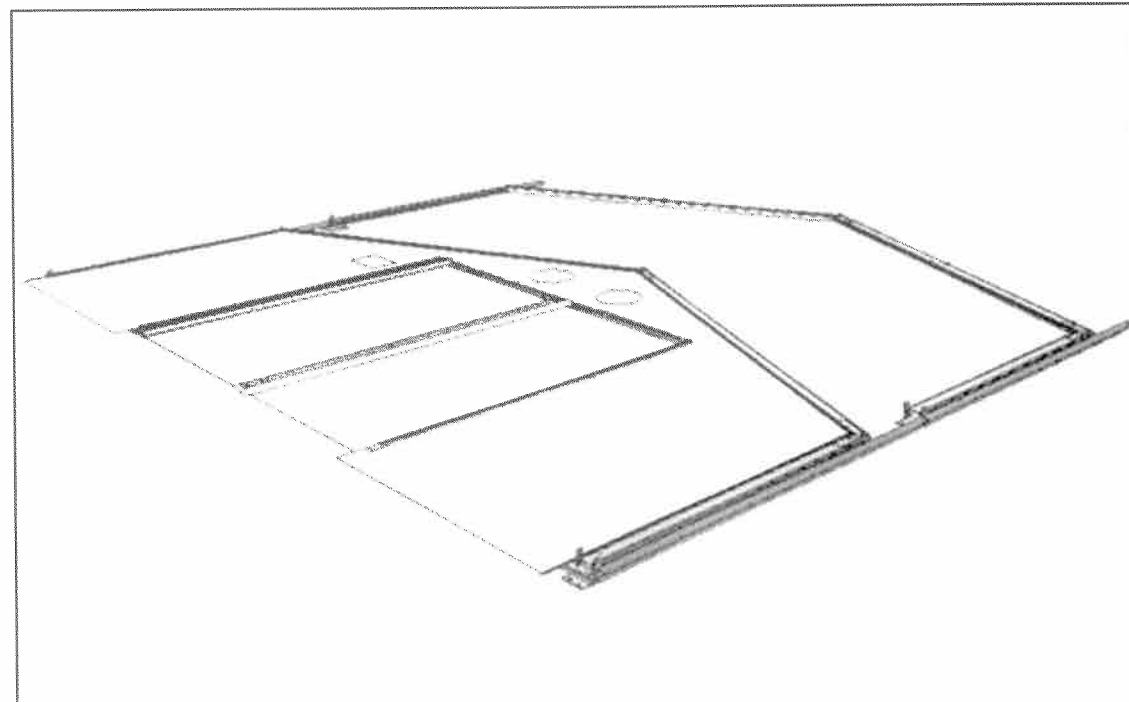

3.3 How to rise the portals.

3.3.1 Rising the first complete portal.

The portal must be lifted carefully to vertical position.
Secure the portal with manpower/rope

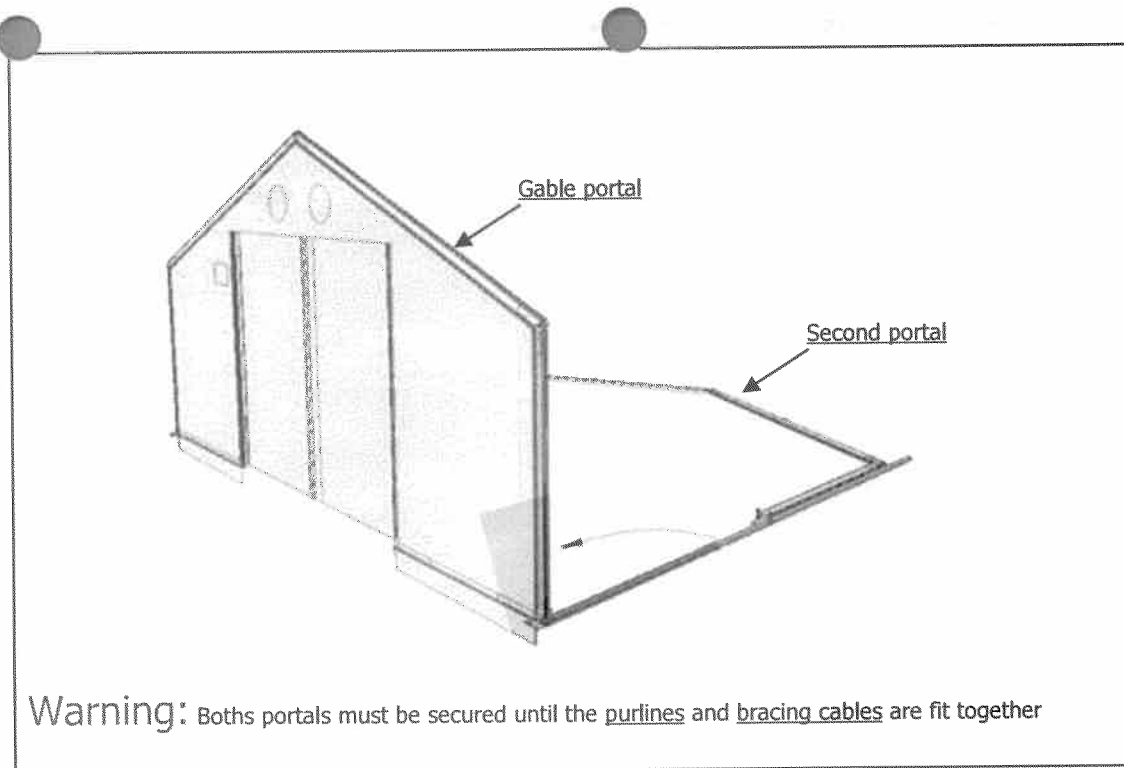

Warning: Both portals must be secured until the purlines and bracing cables are fit together

3.3.2 Second portal.

This portal is erected like the first portal.

ATTENTION!

The purlin, item13 and the counter bracing cables, item15 must as soon as possible be mounted in order to prevent the portals from collapsing.

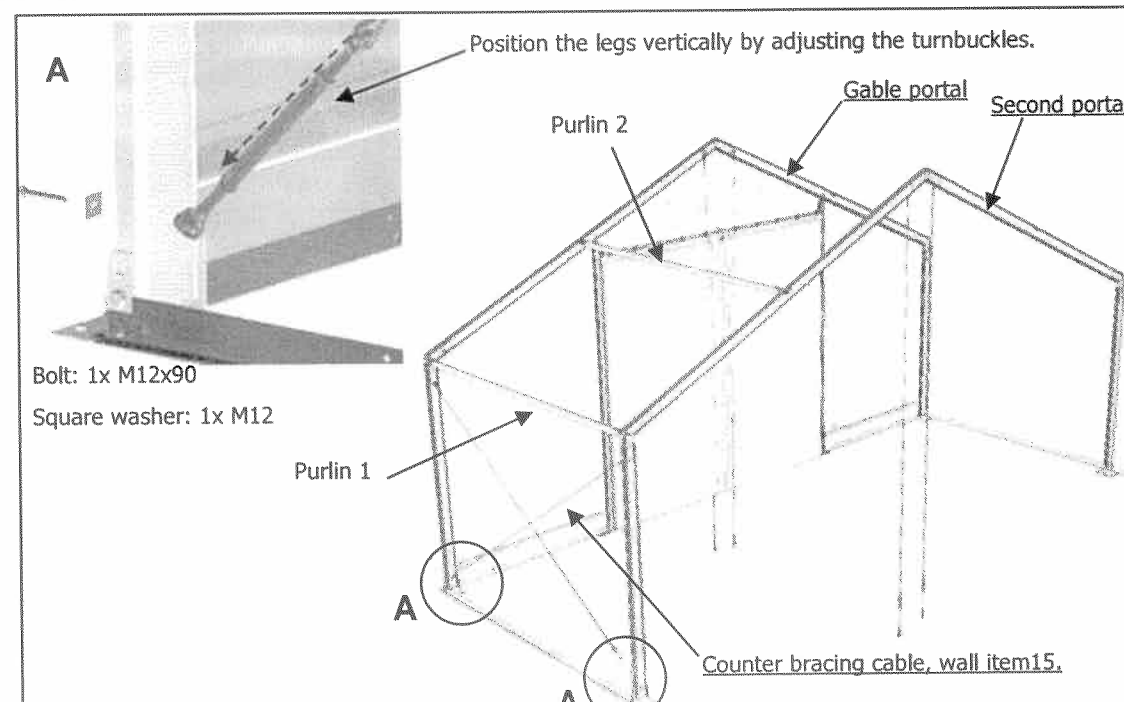

3.3.3 The ridge purlin must be erected by using the lifting fork.

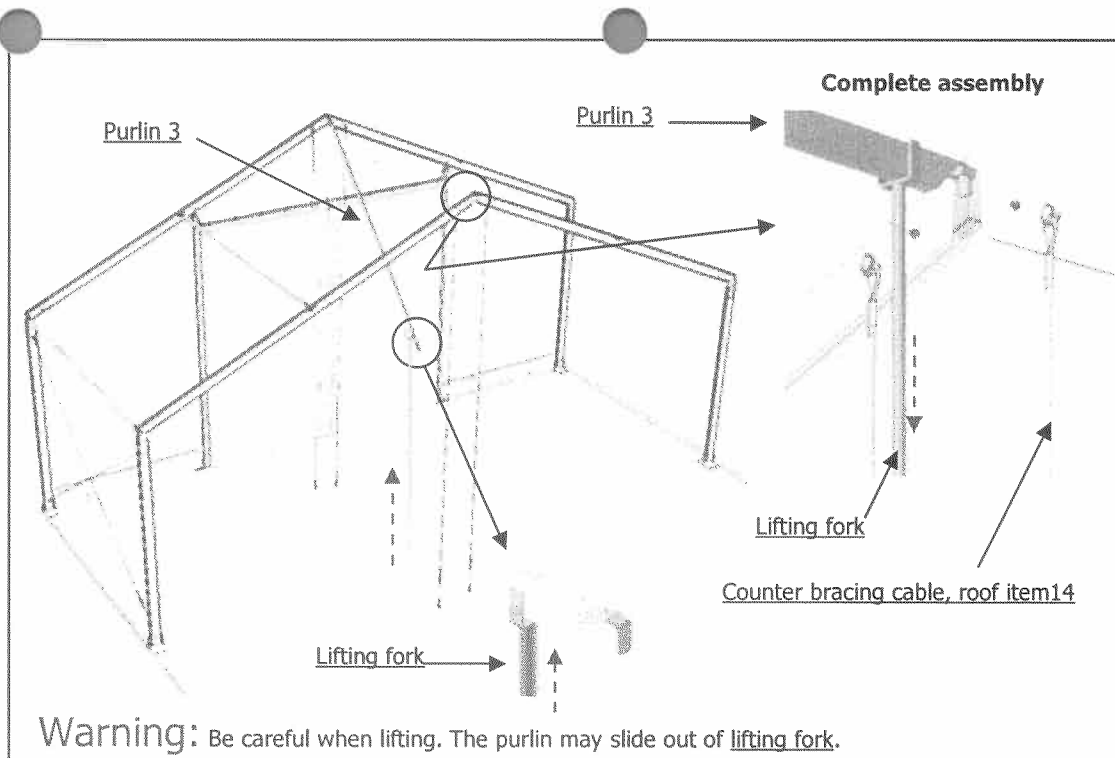

3.3.4 Repeat as described on opposite side.

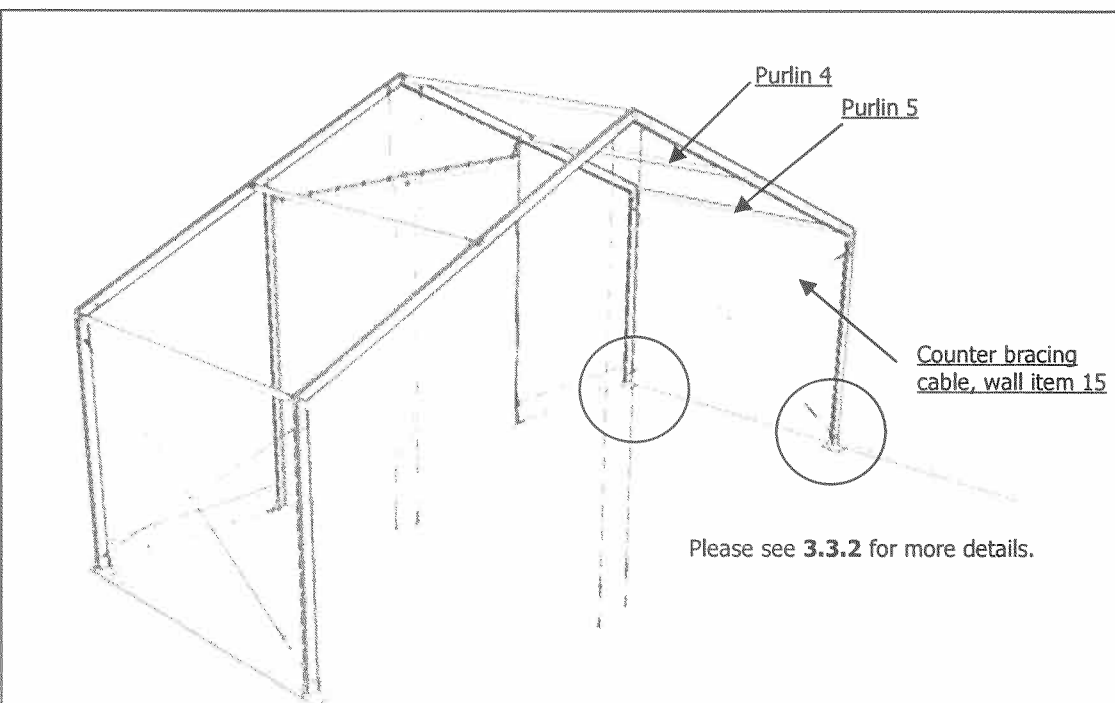

3.3.5 Counter bracing cables, item 14.

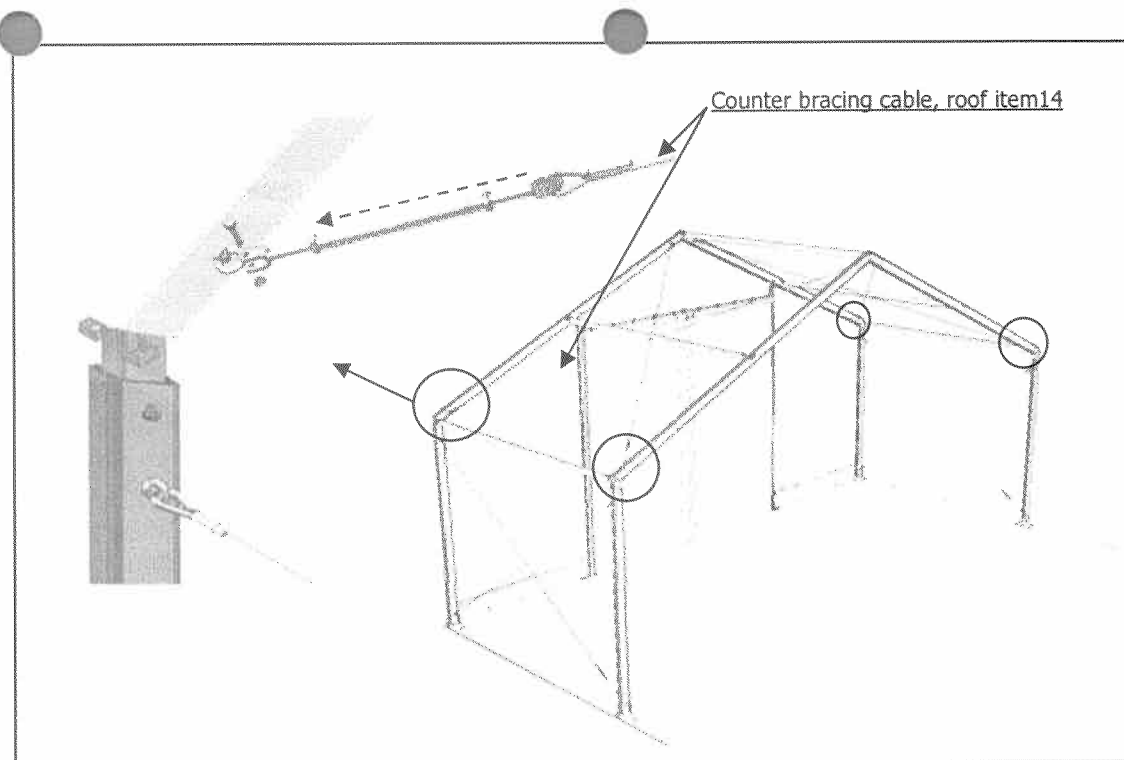

3.3.6 Third portal etc...

This portal is erected in the same way as the other portals. 5 purlines, item 13 must be used for each section.

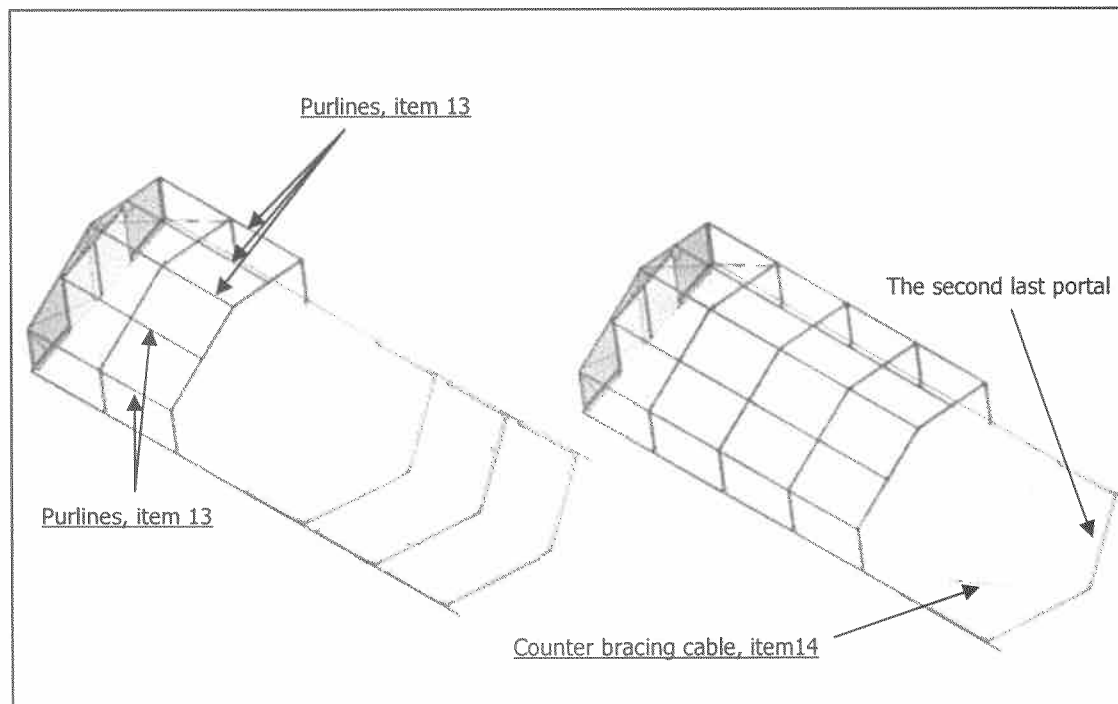

3.3.7 The second last portal is erected in the same way as the gable portal.

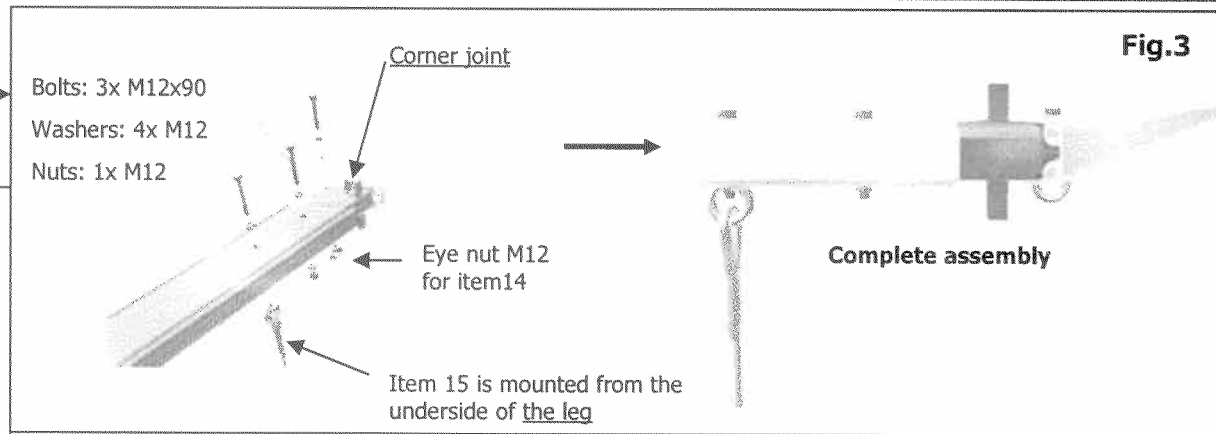
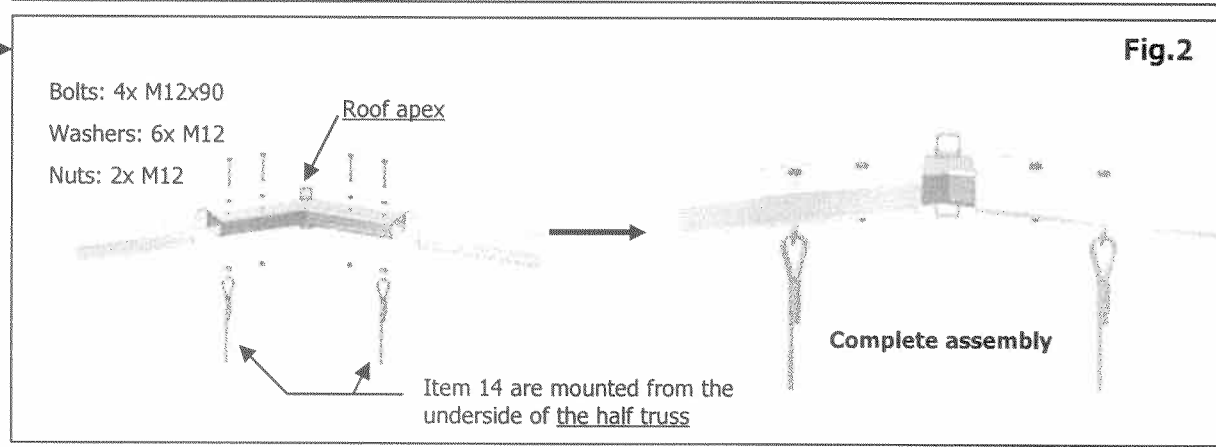
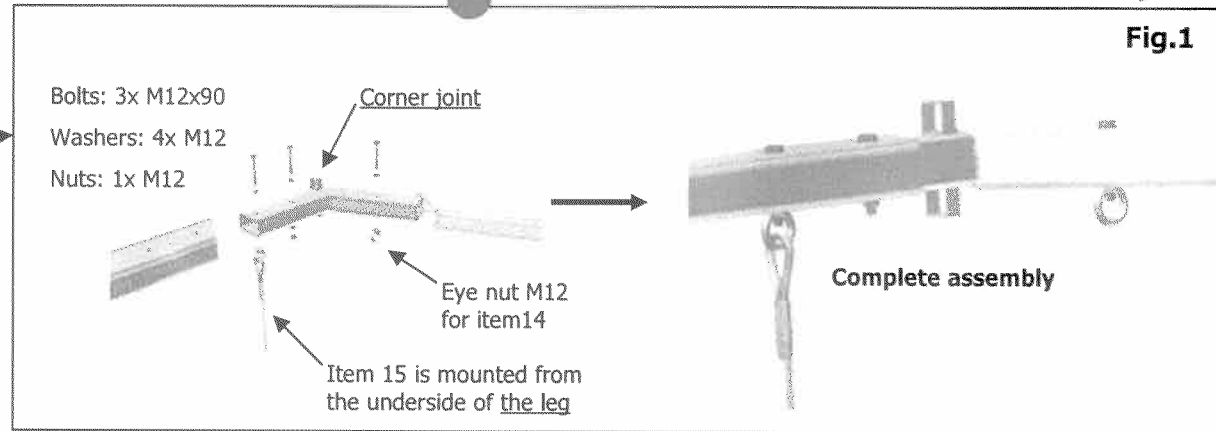
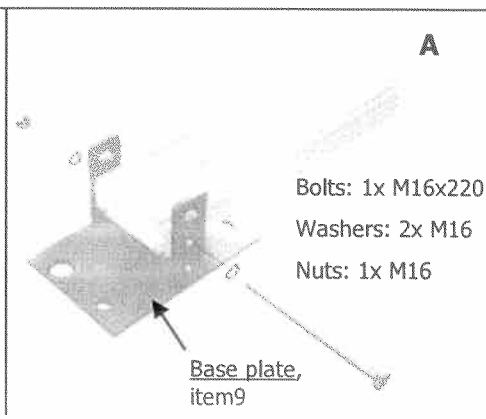
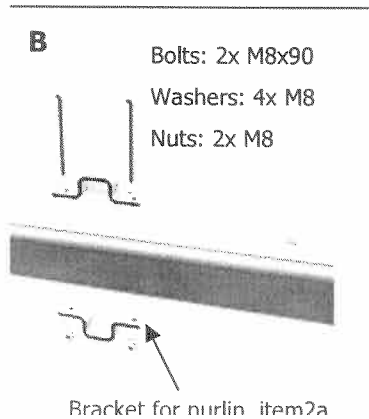
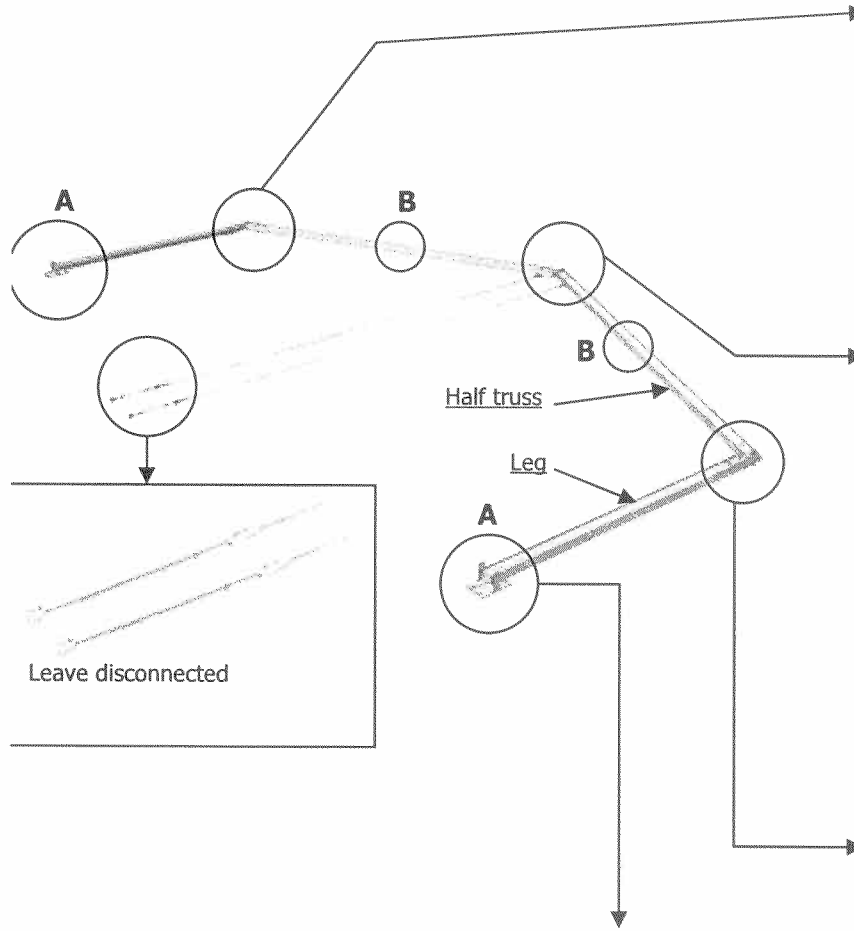

3.3.8 This gable portal must be assembled in the same way as the first gable portal, but erected from the opposite side, in order to fix the gable cover to the outside of the structure.

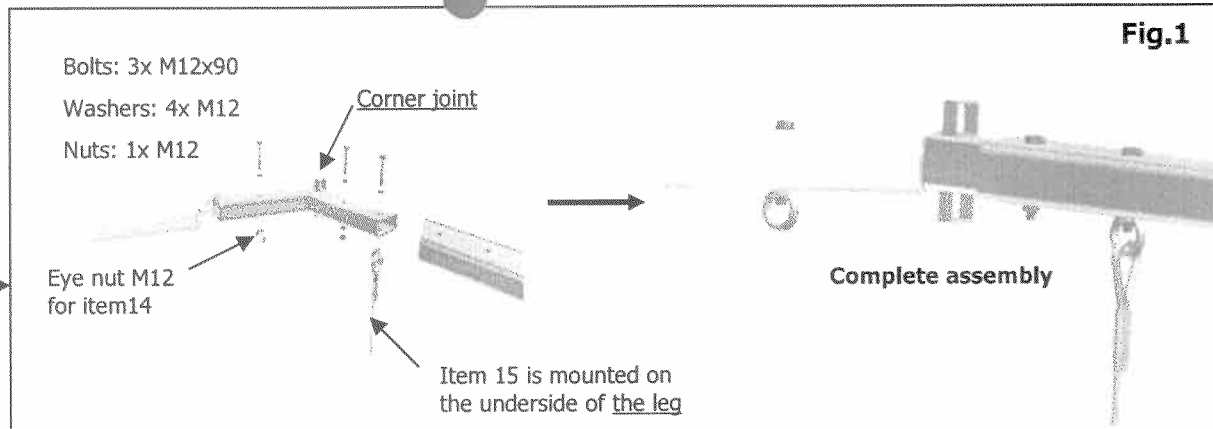
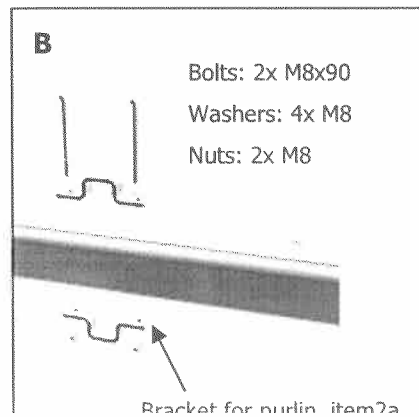
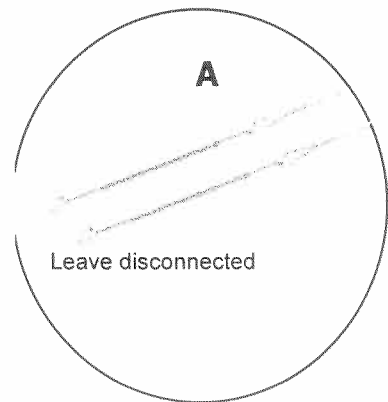
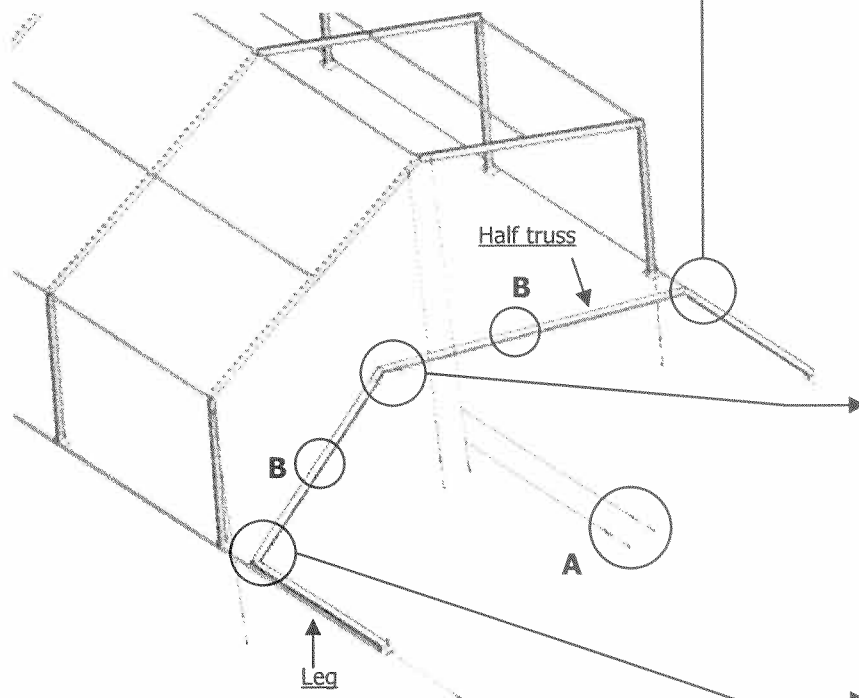

Fig.1

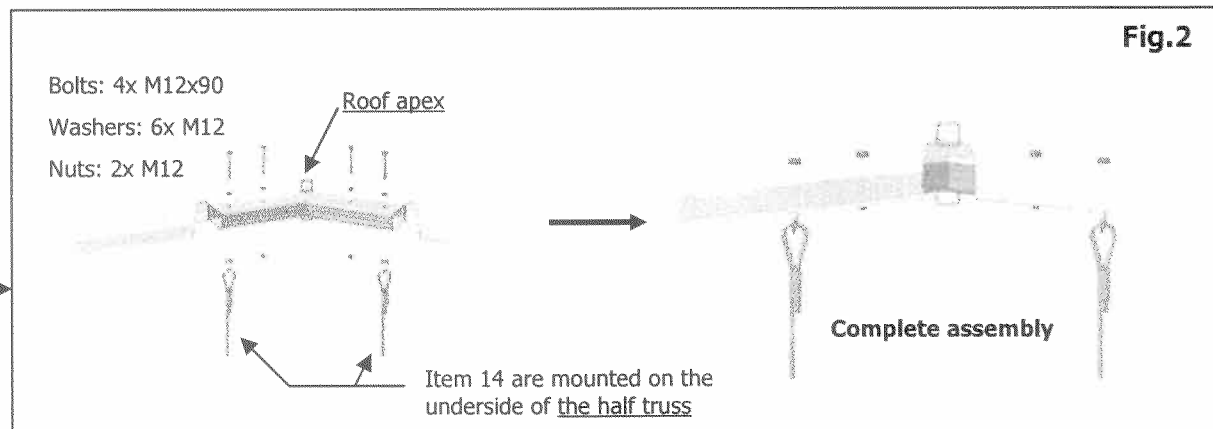

Fig.2

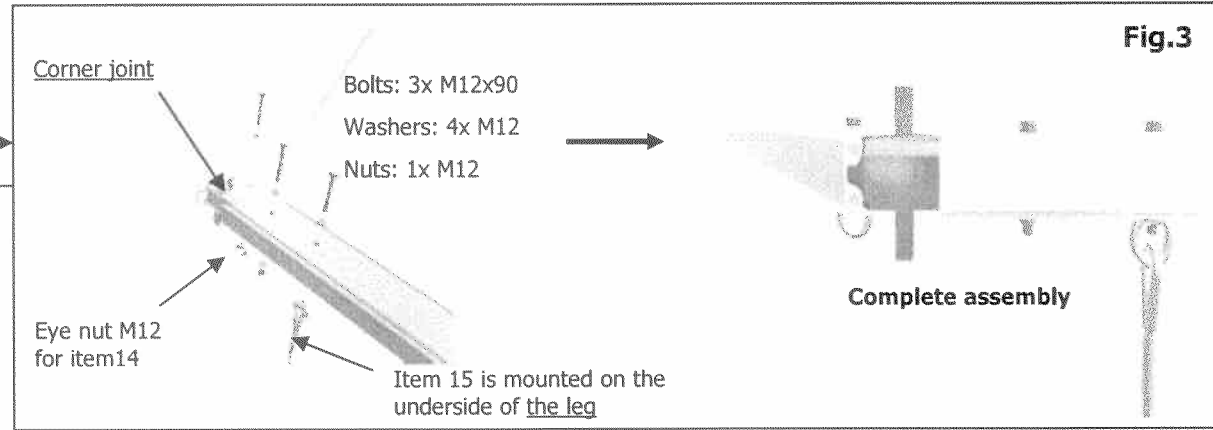
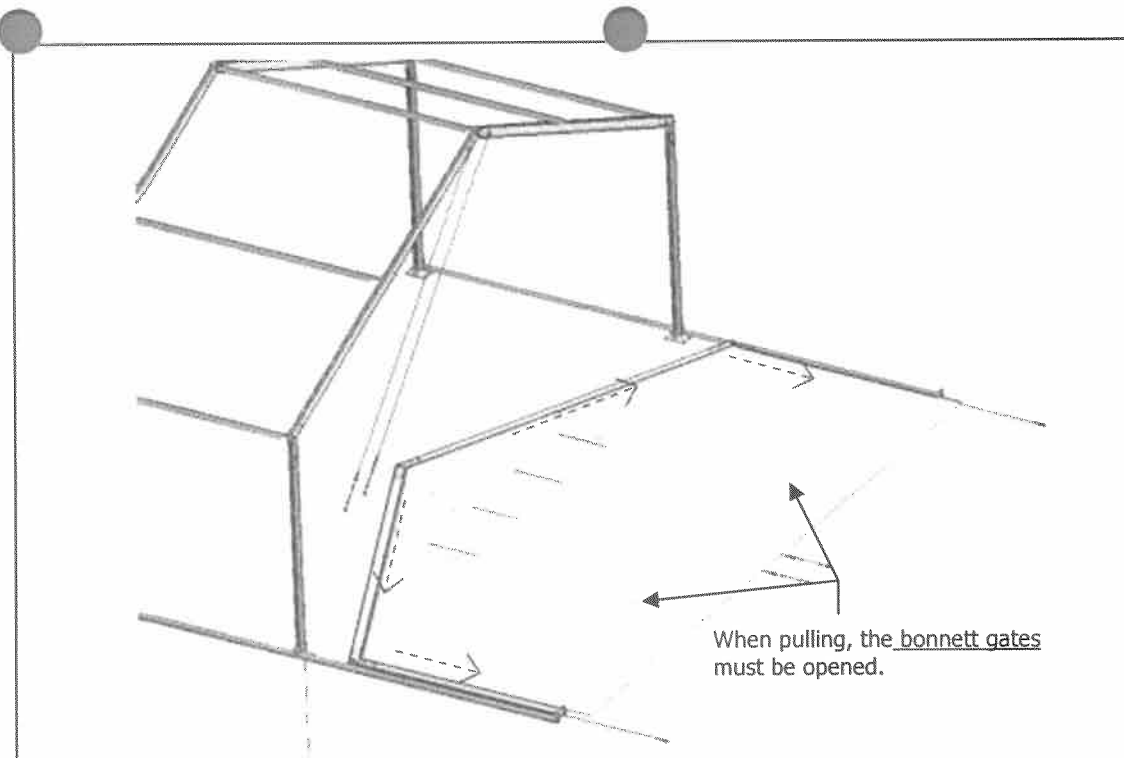

Fig.3

3.4 The gable end B.

3.4.1 How to fit the cover, gable end B.

Please see 3.2.1 for more details.



Please see 3.2.3 and 3.2.4 for more details.

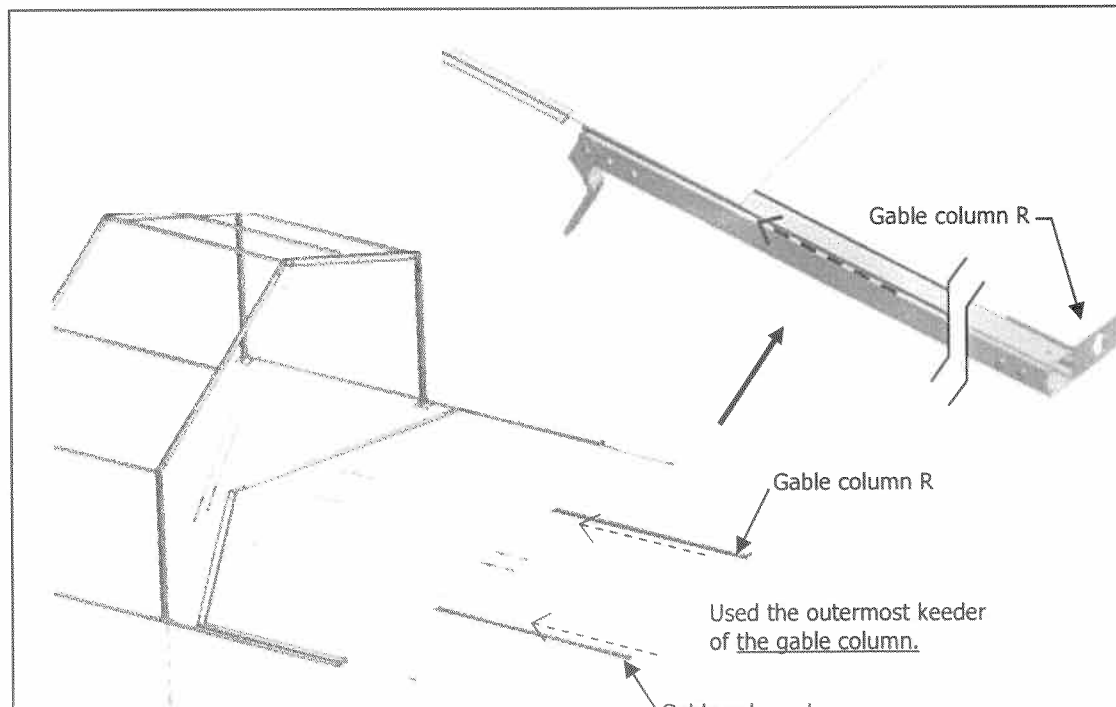

3.5 How to erect the final gable end.

3.5.1 The final gable end.

To complete the erection of the frame.

Please see 3.3.1 – 3.3.5

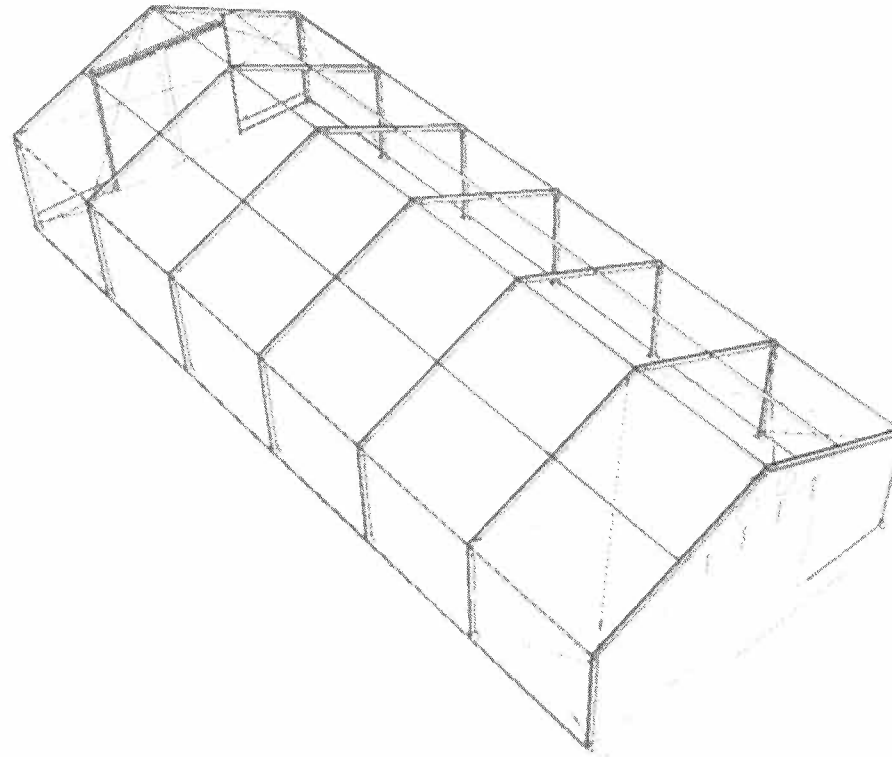

3.6 Anchoring

3.6.1 How to anchor the baseplates.

After erecting the gable portal (final portal), anchor the base plates by fastening 2 spikes to each base plate.

Attach a supplementary bolt M16x220 through each base plate and leg.

These operations must be done all the way around the structure.

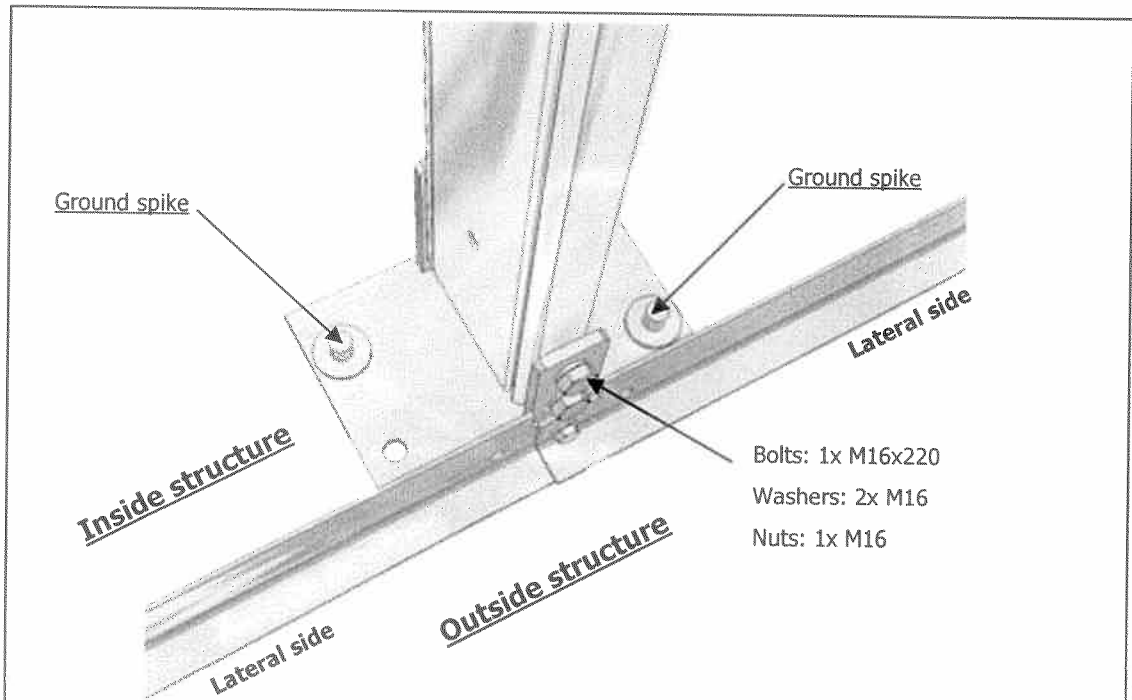
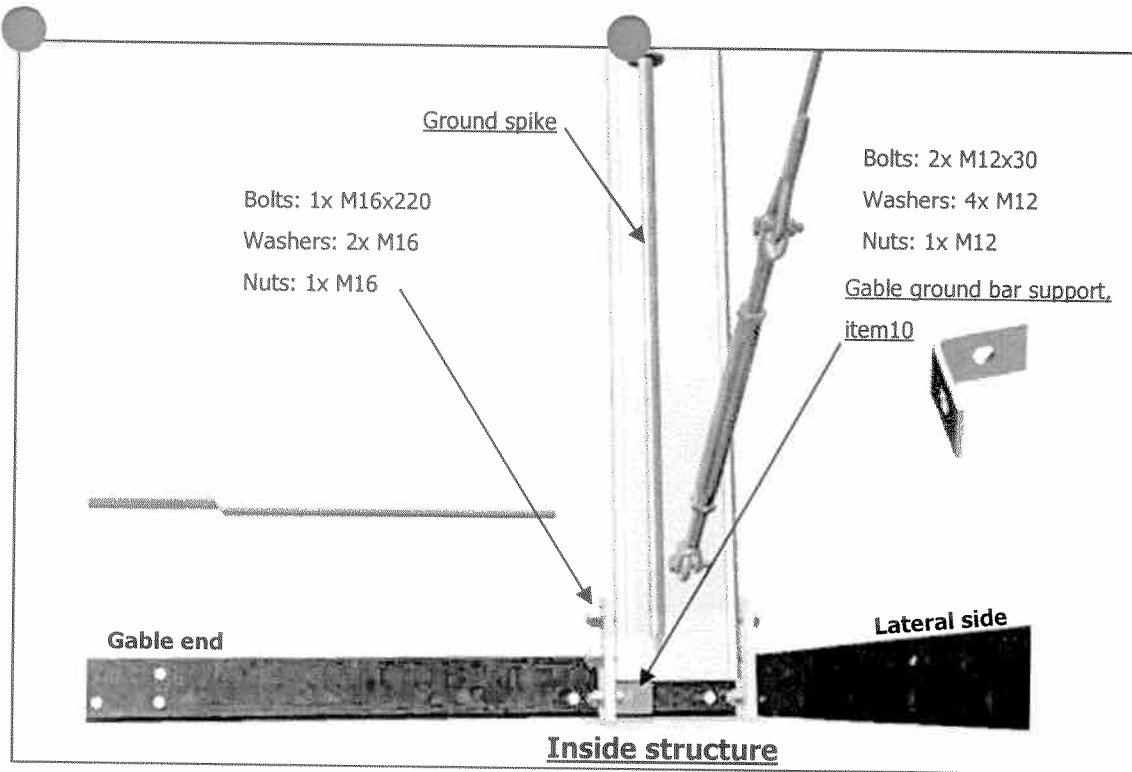

3.7 How to fit the roof cover, item20.



Fig.1 Throw two ropes to the opposite side.



Fig.2 Tie the rope to the web loop located in the corners of the roof covers.



Fig.3 Fit the kederbolt into the keder track of the half truss on both portals

3.7.1 Fitting the roof cover section by section.

Each roof cover must be fit by ropes. Please see Fig.2

Pull the roof cover into position from the opposite lateral side of the structure.

Note: The pockets must be on the inside of the structure.

The diagram shows a 3D perspective view of a roof cover being pulled into a structure. An arrow points to the cover with the label "Roof cover, item 20". Another arrow points to a specific part of the cover labeled "Pocket". A close-up inset shows a pocket being inserted into a track, with an arrow pointing to it labeled "Pocket".

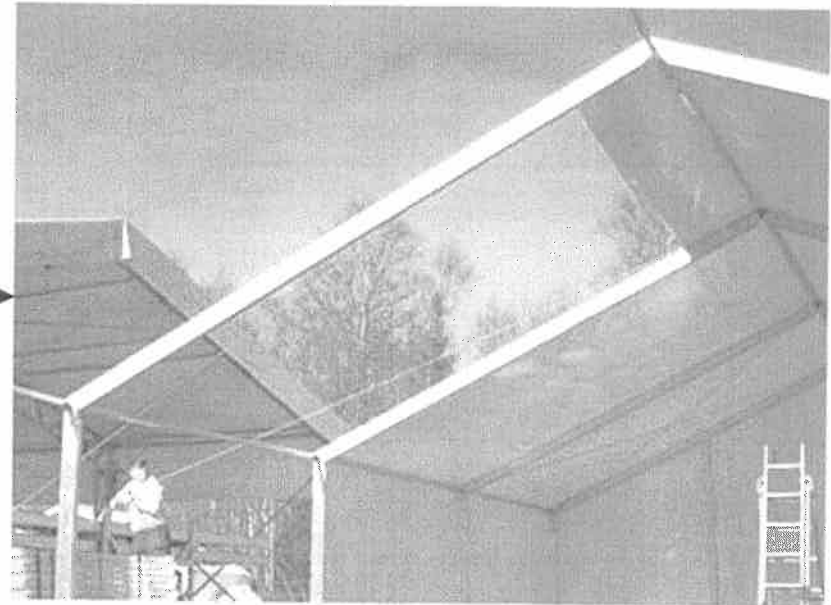
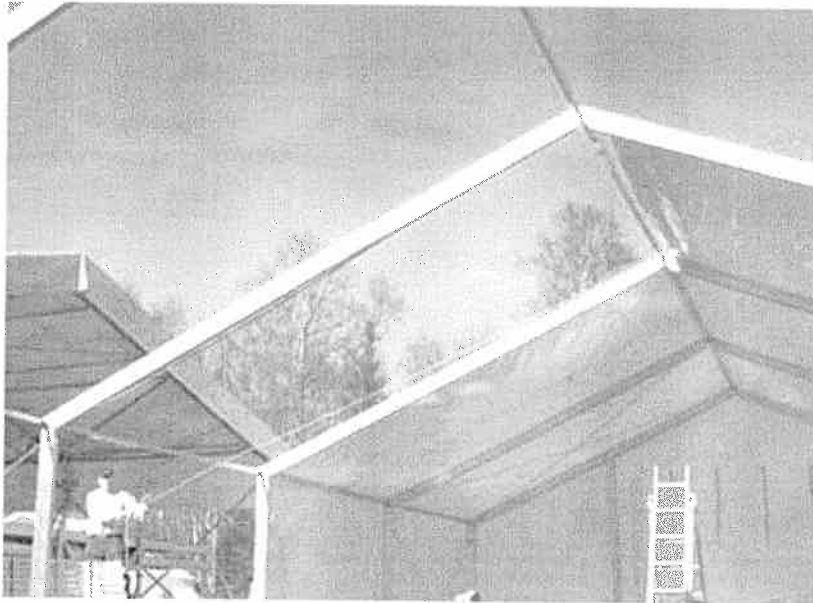

Stop and wait about 3-5 cm from the ridge purlin. Count **1-2-3** and pull simultaneously.

3.7.2 Pull the cover to the opposite side.

Note: Adjust the roof cover until it is in the right position. The lengths are equal on both ends.

